

D
C
B
A

D
C
B
A

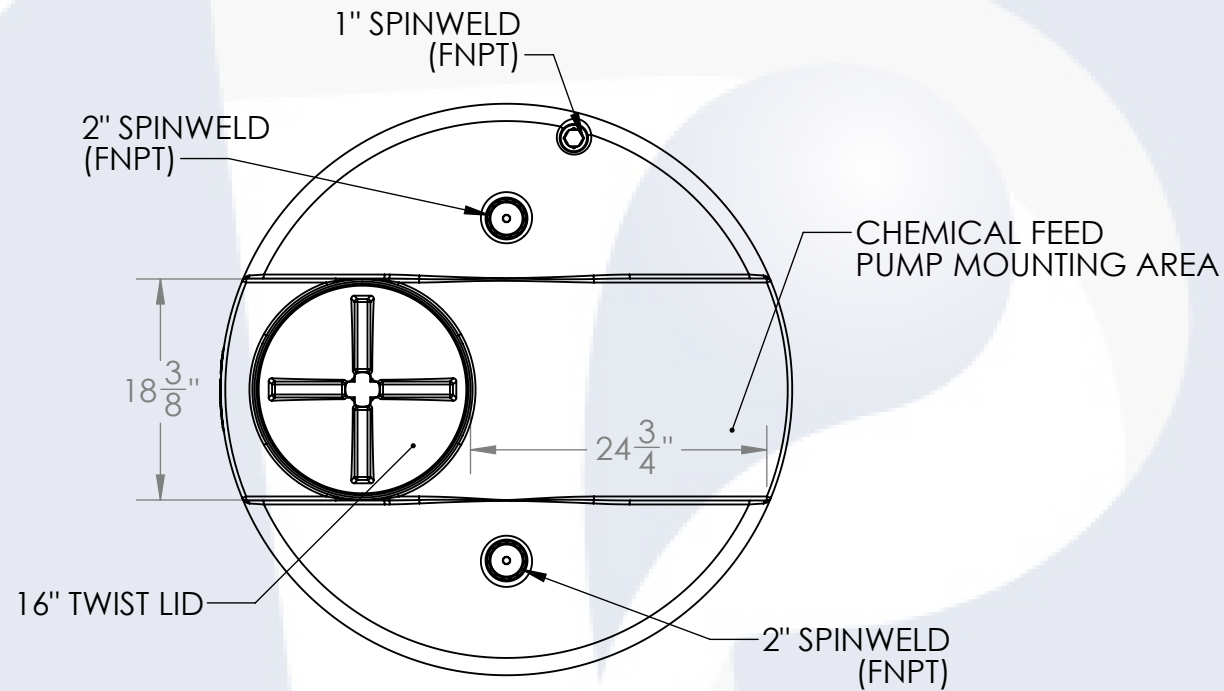

ISOMETRIC VIEW



PLAN VIEW

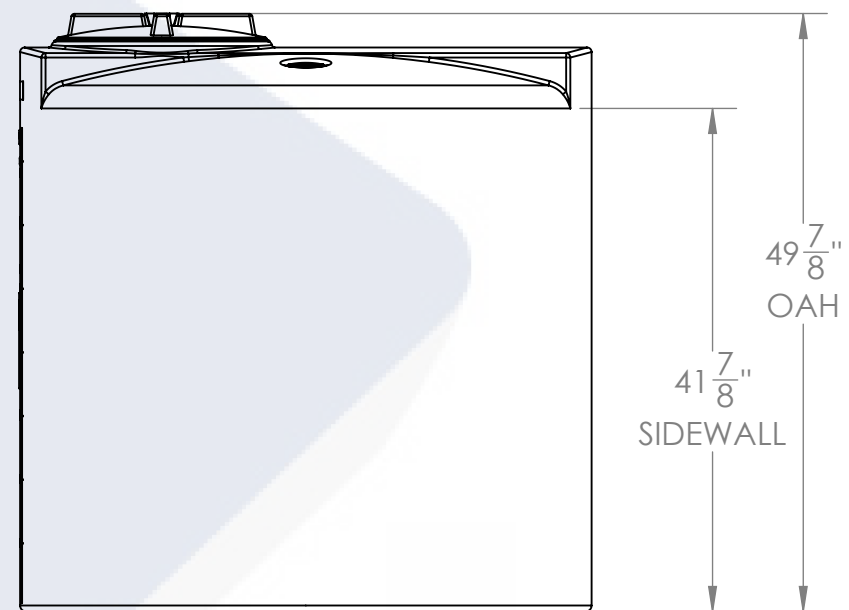

FRONT VIEW

300 GAL PROCHEM® PROCESS TANK, Ø48" x 50"	PART NUMBER	
	PROCESS CHEMICAL (NATURAL)	POTABLE WATER (BLACK)
LPE (1.0)	01-34033	01-31873
LPE (1.5)	01-31277	N/A
LPE (1.9)	01-31268	N/A
XLPE (1.9)	01-31328	N/A
ALTERNATIVE MATERIALS, COLOR, AND ACCESSORIES ARE AVAILABLE. CALL FOR ADDITIONAL INFO		

- NOTES:**
- CAPACITY: 300 GAL. NOMINAL
 - TANK MATERIAL OPTIONS: LPE 1.5, LPE 1.9, XLPE, FDA WATER, PPL, PVDF
 - SERVICE PRESSURE: ATMOSPHERIC
 - NSF/ANSI STANDARD 61 CERTIFIED
 - AVAILABLE W/FRP WRAP
CONTACT CUSTOMER SERVICE FOR MORE INFO

PROPRIETARY AND CONFIDENTIAL
THE INFORMATION CONTAINED IN THIS DRAWING IS THE SOLE PROPERTY OF PEABODY ENGINEERING. ANY REPRODUCTION IN PART OR AS A WHOLE WITHOUT THE WRITTEN PERMISSION OF PEABODY ENGINEERING IS PROHIBITED.

UNLESS OTHERWISE SPECIFIED:
DIMENSIONS ARE IN INCHES
TOLERANCES: ±1/4"
ANGULAR: ± .5°
ONE PLACE DECIMAL: ± .25
TWO PLACE DECIMAL: ± .125
THREE PLACE DECIMAL: ± .063

TANK MATERIAL:
INNER TANK S/N:
OUTER TANK S/N:
CUSTOMER PO#

DO NOT SCALE DRAWING

	NAME	DATE
DRAWN	AAF	11/01/19
CHECKED		
ENG APPR.		
MFG APPR.		
Q.A.		

PEABODY engineering

PROJECT: **PROCHEM® TANKS**

CUSTOMER: **PEABODY STANDARD**

SITE/LOCATION: **-**

SALES ORDER: **SEE TABLE**

SIZE	DESC.	REV.
B	300 GAL PROCHEM® PROCESS TANK, Ø48" x 50"	B

SCALE: 1:16 SHEET 1 OF 1