

D
C
B
A

D
C
B
A

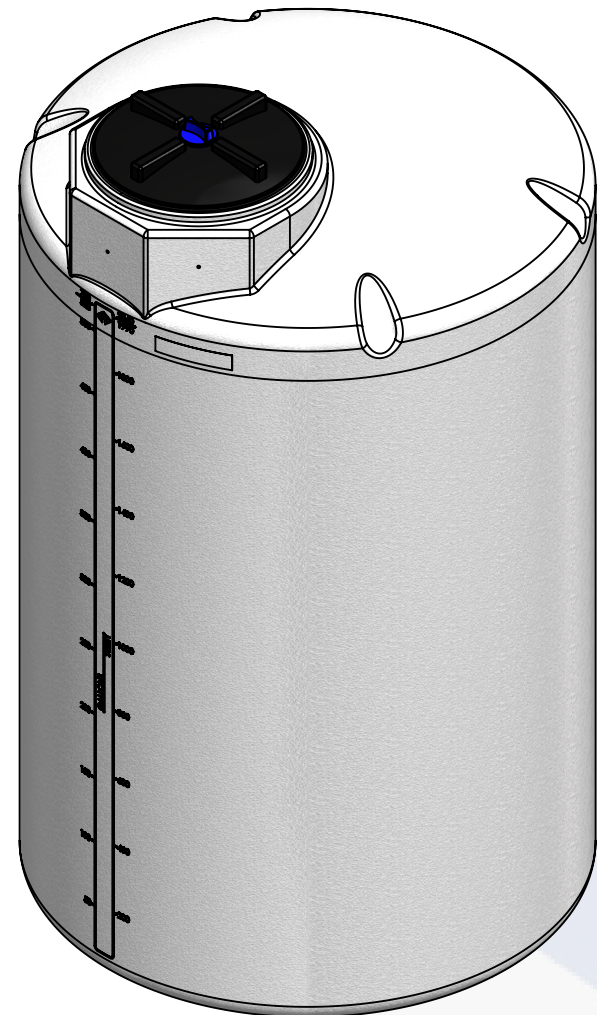

ISOMETRIC VIEW

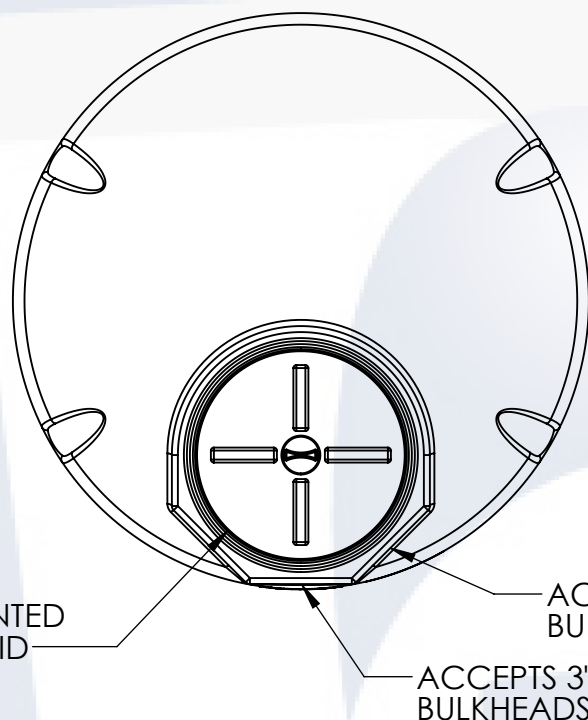

PLAN VIEW

16" VENTED TWIST LID

ACCEPTS 3" BULKHEADS

ACCEPTS 2" BULKHEADS, TYP.

68 7/8" SIDEWALL

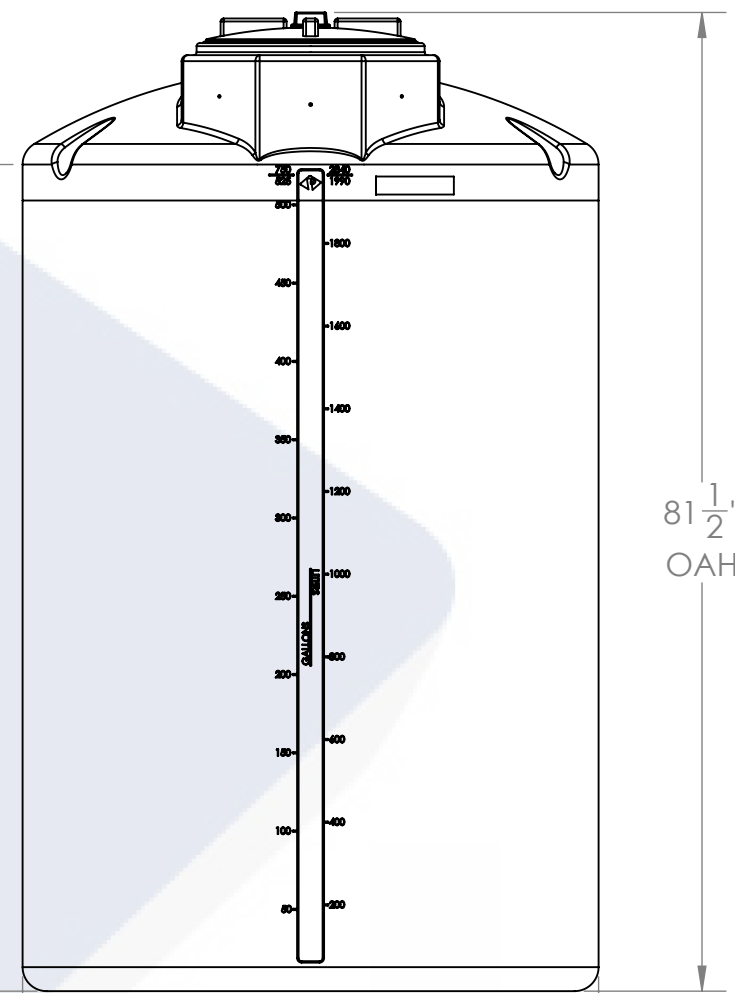

FRONT VIEW

81 1/2" OAH

Ø 48" TANK OD

525 GAL PROCHEM® PROCESS TANK, Ø48" x 82"	PART NUMBER	
	PROCESS CHEMICAL (NATURAL)	POTABLE WATER (BLACK)
LDPE (1.0)	01-34034	01-31874
LDPE (1.5)	01-31278	N/A
LDPE (1.9)	01-31270	N/A
XLPE (1.9)	01-31330	N/A

ALTERNATIVE MATERIALS, COLOR, AND ACCESSORIES ARE AVAILABLE. CALL FOR ADDITIONAL INFO

- NOTES:**
- CAPACITY: 525 GAL. NOMINAL
 - TANK MATERIAL OPTIONS: LPE 1.5, LPE 1.9, XLPE, FDA WATER, PPL, PVDF
 - SERVICE PRESSURE: ATMOSPHERIC
 - NSF/ANSI STANDARD 61 CERTIFIED
 - AVAILABLE W/FRP WRAP
CONTACT CUSTOMER SERVICE FOR MORE INFO

PROPRIETARY AND CONFIDENTIAL
THE INFORMATION CONTAINED IN THIS DRAWING IS THE SOLE PROPERTY OF PEABODY ENGINEERING. ANY REPRODUCTION IN PART OR AS A WHOLE WITHOUT THE WRITTEN PERMISSION OF PEABODY ENGINEERING IS PROHIBITED.

UNLESS OTHERWISE SPECIFIED:
DIMENSIONS ARE IN INCHES
TOLERANCES: ±1/4"
ANGULAR: ± .5°
ONE PLACE DECIMAL: ± .25
TWO PLACE DECIMAL: ± .125
THREE PLACE DECIMAL: ± .063

TANK MATERIAL:
INNER TANK S/N:
OUTER TANK S/N:
CUSTOMER PO#

DO NOT SCALE DRAWING

	NAME	DATE
DRAWN	AAF	11/01/19
CHECKED		
ENG APPR.		
MFG APPR.		
Q.A.		



PROJECT: PROCHEM® TANKS		REV. A
CUSTOMER: PEABODY STANDARD		
SITE/LOCATION: -		SCALE: 1:16
DRAWING#: SEE TABLE		
SIZE B	DESC. 525 GAL PROCHEM® PROCESS TANK, Ø48" x 82"	SHEET 1 OF 1