

ISOMETRIC VIEW

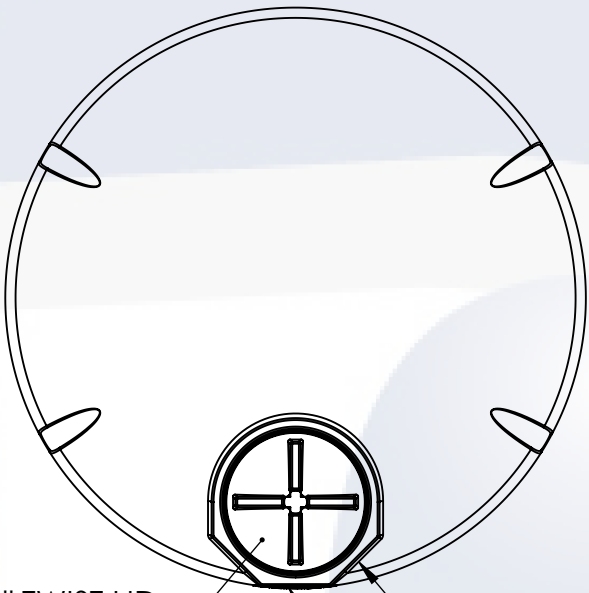

PLAN VIEW

16" TWIST LID
ACCEPTS 2" BULKHEADS, TYP.
ACCEPTS 3" BULKHEADS

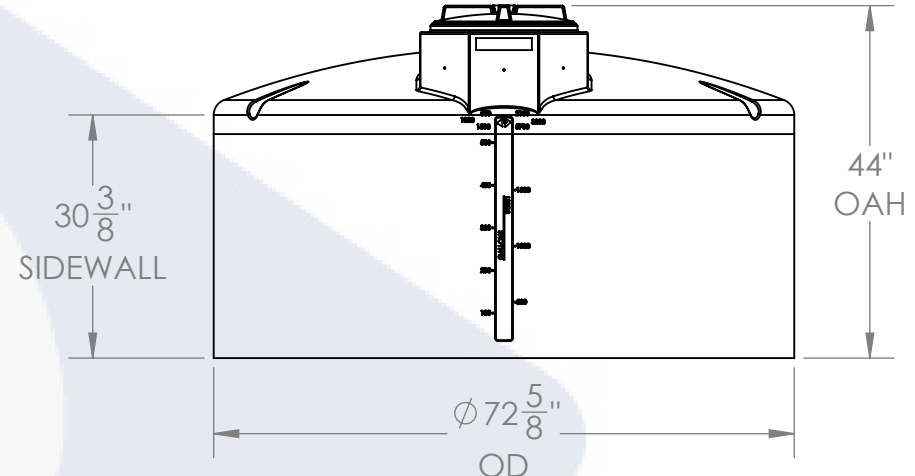

FRONT VIEW

550 GAL PROCHEM® PROCESS TANK 72.625 X 44	PART NUMBER	
	PROCESS CHEMICAL (NATURAL)	POTABLE WATER (BLACK)
LPE (1.0)	01-34035	01-33432
LPE (1.5)	01-33429	N/A
LPE (1.9)	01-33430	N/A
XLPE (1.9)	01-33431	N/A

ALTERNATIVE MATERIALS, COLOR, AND ACCESSORIES ARE AVAILABLE. CALL FOR ADDITIONAL INFO

- NOTES:**
- CAPACITY: 550 GAL. NOMINAL
 - TANK MATERIAL OPTIONS: LPE 1.5, LPE 1.9, XLPE, FDA WATER, PPL, PVDF
 - SERVICE PRESSURE: ATMOSPHERIC
 - NSF/ANSI STANDARD 61 CERTIFIED
 - AVAILABLE W/FRP WRAP
CONTACT CUSTOMER SERVICE FOR MORE INFO

PROPRIETARY AND CONFIDENTIAL
THE INFORMATION CONTAINED IN THIS DRAWING IS THE SOLE PROPERTY OF PEABODY ENGINEERING. ANY REPRODUCTION IN PART OR AS A WHOLE WITHOUT THE WRITTEN PERMISSION OF PEABODY ENGINEERING IS PROHIBITED.

UNLESS OTHERWISE SPECIFIED:
DIMENSIONS ARE IN INCHES
TOLERANCES: ±1/4"
ANGULAR: ±.5°
ONE PLACE DECIMAL: ±.25
TWO PLACE DECIMAL: ±.125
THREE PLACE DECIMAL: ±.063

TANK MATERIAL:
INNER TANK S/N:
OUTER TANK S/N:
CUSTOMER PO#

DO NOT SCALE DRAWING

	NAME	DATE
DRAWN	SMF	02/08/22
CHECKED		
ENG APPR.		
MFG APPR.		
Q.A.		

			PROJECT:	PROCHEM® TANKS	
			CUSTOMER:	PEABODY STANDARD	
			SITE/LOCATION:	-	
			SALES ORDER:	SEE TABLE	
SIZE	DESC.	REV.			
B	550 GAL PROCHEM® PROCESS TANK 72.625 X 44	-			
SCALE: 1:24			SHEET 1 OF 1		