

**ISOMETRIC VIEW**

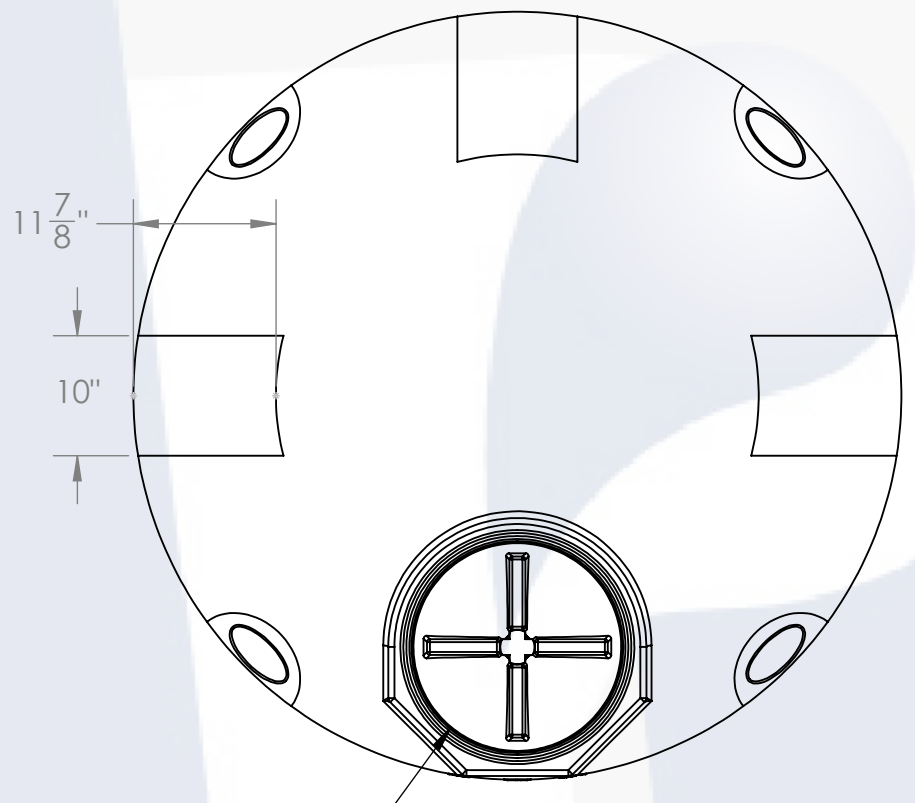

**PLAN VIEW**

16" TWIST LID

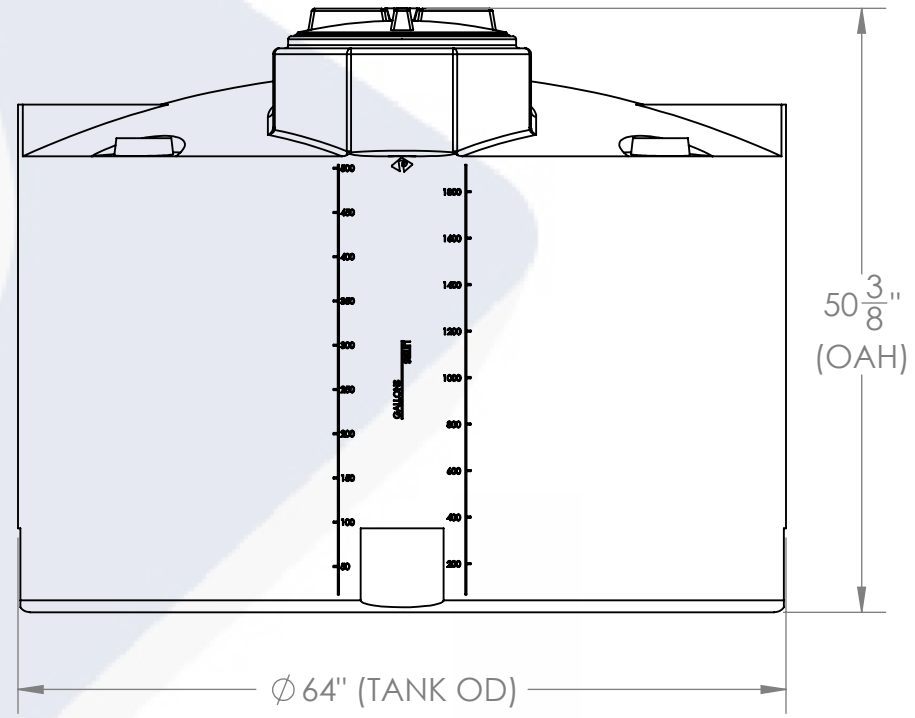

**FRONT VIEW**

- NOTES:**
1. CAPACITY: 575 GAL. NOMINAL
  2. TANK MATERIAL OPTIONS:  
LPE 1.5, LPE 1.9, XLPE, FDA WATER, PPL, PVDF
  3. SERVICE PRESSURE: ATMOSPHERIC
  4. NSF/ANSI STANDARD 61 CERTIFIED
  5. AVAILABLE W/FRP WRAP  
CONTACT CUSTOMER SERVICE FOR MORE INFO

**PROPRIETARY AND CONFIDENTIAL**  
THE INFORMATION CONTAINED IN THIS DRAWING IS THE SOLE PROPERTY OF PEABODY ENGINEERING. ANY REPRODUCTION IN PART OR AS A WHOLE WITHOUT THE WRITTEN PERMISSION OF PEABODY ENGINEERING IS PROHIBITED.

UNLESS OTHERWISE SPECIFIED:		NAME	DATE	
DIMENSIONS ARE IN INCHES TOLERANCES: ±1/4" ANGULAR: ± .5° ONE PLACE DECIMAL: ± .25 TWO PLACE DECIMAL: ± .125 THREE PLACE DECIMAL: ± .063		DRAWN	JO 01/15/24	
TANK MATERIAL:		CHECKED		
INNER TANK S/N:		ENG APPR.		
OUTER TANK S/N:		MFG APPR.		
CUSTOMER PO#		Q.A.		PROJECT: <b>PROCHEM® TANKS</b>
				CUSTOMER: <b>PEABODY STANDARD</b>
				SITE/LOCATION: -
				SALES ORDER: <b>SEE TABLE</b>
				SIZE: <b>B</b> DESC. <b>575 GAL PROCHEM® TANK, Ø64" x 49"</b> REV. -
				SCALE: 1:16    SHEET 1 OF 1