

**High Intelligence.....Low Technology**



**Constant Pressure Pump Control Valves**

[www.CycleStopValves.com](http://www.CycleStopValves.com)



# Table of Contents

What are Cycle Stop Valves?	3
How Cycle Stop Valves Affect Pumps and Motors	4
Easy Selection Chart	5
Model CSV125-1/CSV125-1 and CSV125-3/CSV125-3	6
Model CSV125/CSV125 Specifications	8
Model CSV1A, CSV2W	9
Model CSV1A Specifications	11
Model CSV2W Specifications	12
Application Information Model CSV1 and CSV2	13
Model CSV3 A or B	14
Model CSV3 A or B Principle of Operation	16
Model CSV3 A Specifications	17
Model CSV3 B Specifications	18
Model CSV3 A or B Operating Data	19
Model CSV3R	20
Model CSV3R Principle of Operation	22
Model CSV3R Specifications	23
Model CSV3R Flow Chart	24
Model CSV3R Operating Data	25
Application Information Model CSV3	26
Model CSV3R and CSV3B Pilot Specifications	27
Model PK1A pside-kick complete pump control kit	28
Cycle Sensor	32
Pressure Tank Sizing	35

[www.CycleStopValves.com](http://www.CycleStopValves.com)  
[info@cyclestopvalves.com](mailto:info@cyclestopvalves.com)

800-652-0207 or  
806-885-4445

11/01/20

# What are Cycle Stop Valves?



The Cycle Stop Valve is a pump control valve that makes a variable flow, constant pressure pump out of most standard, constant speed pumps.

Installed between the pump and your water system, the Cycle Stop Valve (CSV) automatically chokes back the output of a pump to match the users demand for water.

As the gallons per minute decrease, the amperage draw decreases as well because it is the weight of the water that determines the horse power or amperage needed, not the pressure.

The CSV maintains a constant pressure for the water user when demand is within the recommended range for the valve model being used.

It is completely mechanical and pressure actuated. No electricity required.

Constant speed pumps are now capable of providing constant pressure in variable demand situations without expensive controls, huge pressure tanks, or water towers. Pumps equipped with a CSV can operate safely from as low as 1 gpm to as much as the pump can produce.

The CSV stops pump cycling, eliminates water hammer, extends pump life, and reduces energy costs compared to a system allowed to cycle off and on excessively when demand varies.



86 gallon tank replaces 10,000 gallon tank



86 gallon tank replaces 30,000 gal standpipe



# How Cycle Stop Valves Affect Pumps and Motors

## **Back Pressure?**

As counter intuitive as it may seem, increasing back pressure does not make pumps work harder. One horse power is the measure of power it takes to lift 33,000 pounds of weight (or 3,750 gallons) one foot in one minute. Gallons and weight are the same thing to the pump. If flow from the pump is restricted with a valve, back pressure will increase. As back pressure increases, gallons or weight decreases. As the weight or gallons of water being lifted by the pump decreases, so does power consumption, amps, or horse power. Excess back pressure is a free by-product of horsepower. Back pressure makes pumps pull less amperage, not more. Less amperage means motors run cooler, use less electricity, and last longer.

## **Minimum Flow?**

While Cycle Stop Valves will increase back pressure on pumps when needed, they will never let the back pressure increase to complete shut off head. The Cycle Stop Valve can never completely close. There is always water flowing through the valve even when in its fully closed position. This flow is derived from the minimum cooling requirements of the pump and motor. Large submersible pumps can operate on much smaller flows than .5 feet per second. Flow charts for motors running at FULL LOAD AMPERAGE are not relevant for motors pulling an average 60% of full load. As back pressure increases until the pump is only pumping minimum flow, amperage decreases, derating the motor. When pulling only 50 to 60% of full load, the derated motor can safely pump hot water up to 140 degrees according to the charts. If a derated motor can safely pump any amount of 140 degree water, then a tiny amount of cool water (86 degrees or less) will easily prevent the motor from overheating. Minimum cooling charts for derated motors have not been made available by the motor manufactures. Years of experience has proven many times over that motors such as a 50 HP sub will drop from 77 amps to about 40 amps when the pump is restricted to 5 gpm flow. This 5 gpm flow of 70 degree water going past the motor will increase in temperature to 78 degrees. Seventy eight degrees is not even close to 131 degree water that the charts say can safely cool a 50 HP motor when derated by 40%. Full speed turbines and centrifugal pumps can operate at even lower minimum flows as their motors are cooled by air. Motor and cooling fan are still spinning at full RPM, which will keep a motor that is only pulling 60% of full load amps very cool.

## **Resting Pumps and Motors?**

Pumps and motors are designed for continuous operation and do not need to rest. This means they will last longer if they run continuously than if they "cycle" off and on. Motors that are coasting along at low amperage 24 hours a day will use less electricity than the same motor pulling full load and cycling on and off every 10 minutes or so. Most motor and pump failures occur during start up. Starting current can be six times normal running amperage. Start up tests every component of the pump and motor. Windings, bearings, shafts, impellers, splines, couplings, panels, even the generator at the power company are all tested each time a pump starts. All of these problems go away once the motor is up and running. Common sense would suggest that the fewer times it starts and stops, the longer a motor and pump will last.

## **Soft Start Equipment?**

Some electric companies require soft starts on larger horse power systems. Cycle Stop Valves will completely eliminate water hammer with or without electrical soft start equipment and will also provide the same no load start up comparable to any electrical soft start equipment. This will reduce the electric bill if a demand charge is included.

## **Cavitation?**

Restricting the discharge from a pump with any valve will decrease the NPSH required. The NPSH available will increase as the flow rate decreases. Increasing the NPSHA and/or decreasing the NPSHR reduces the chance of cavitation. Recirculating water from the outlet to the inlet of an impeller can occur at low flow. The 5 GPM bypass exiting the Cycle Stop Valve will keep this recirculating from heating up the pump. Cavitation like wear can occur if the pump chosen has a recirculating problem such as with a loose-fitting wear ring. Pumps that are made of materials with a high tensile strength are more resistant to wear from cavitation. When equipped with an additional pressure sustain pilot the Cycle Stop Valve can also control cavitation at high flow rates by limiting the maximum flow from the pump.

# Easy Selection Chart



<u>Flow Range</u>	<u>Maximum pump shut off PSI</u>	<u>Size</u>	<u>Type</u>	<u>Model #</u>
<b>Thermoplastic CSV125-1 and CSV125-3 Model</b>				
1-50 GPM	150 PSI	1 1/4"	THREADED	CSV125/CSV5125(PSI)-1
3-50 GPM	150 PSI	1 1/4"	THREADED	CSV125/CSV5125(PSI)-3
(CSV125 valves are available in preset pressure settings of 40, 50, or 60 PSI. We recommend the -1 model for 2HP or smaller and the -3 model for 3 to 5 HP. Example Model #'s are CSV12540-1 or CSV12550-3)				
<b>Stainless Steel CSV1A Model NSF61</b>				
1-25 GPM	400 PSI	1" female NPT and 1 1/4" male NPT	THREADED	CSV1A
(CSV1A IS AVAILABLE WITH AN ADJUSTMENT RANGE OF 15-150 PSI w/ 150-300 PSI AVAILABLE)				
<b>No lead brass alloy CSV 2W Model</b>				
5-50 GPM	300 PSI	1 1/4"	THREADED	CSV2W1.25T2575
5-50 GPM	300 PSI	1 1/4"	THREADED	CSV2W1.25T50120
(CSV2W AVAILABLE WITH 25-75 PSI OR 50-120 PSI ADJUSTMENT RANGES)				
<b>Polyster Coated Ductile Iron Model CSV3A NSF61</b>				
5-150 GPM	225 PSI	2"	THREADED	CSV3A2T
5-300 GPM	225 PSI	3"	THREADED	CSV3A3T
5-300 GPM	225 PSI	3"	FLANGED	CSV3A3F
5-500 GPM	225 PSI	4"	FLANGED	CSV3A4F
<b>Polyster Coated Cast Iron CSV3B Model</b>				
5-500 GPM	225 PSI	4"	FLANGED	CSV3B4F
5-1200 GPM	225 PSI	6"	FLANGED	CSV3B6F
5-2000 GPM	225 PSI	8"	FLANGED	CSV3B8F
(STANDARD PSI ADJUSTMENT RANGE 15-150, W/150-225 AVAILABLE)				
<b>Stainless Steel CSV "3R" Model</b>				
5-150 GPM	300 PSI	2"	WAFER FLANGE	CSV3R2F
5-300 GPM	300 PSI	3"	WAFER FLANGE	CSV3R3F
5-600 GPM	300 PSI	4"	WAFER FLANGE	CSV3R4F
5-1200 GPM	300 PSI	6"	FLANGE	CSV3R6F
(STANDARD PSI ADJUSTMENT RANGE 15-150, W/150-300 AVAILABLE)				
<b>Always check friction loss charts for your specific flows. Larger valves available...Contact manufacturer</b>				



# - Model - CSV125/CSV125



## **-Model- CSV125/CSV125**



The **CYCLE STOP VALVE** model **CSV125/CSV125** is a pump control valve that automatically adjusts your pump to match your variable demands. This product creates back pressure, that is how it works. Back pressure is determined by the pump you are using. Be sure your piping between the pump and the Cycle Stop Valve is rated for that pressure.

As your demands vary, the **CSV** reacts to the changes in pressure and opens and closes accordingly. This enables it to hold a constant pressure as long as your demand is more than the minimum control flow of 1 or 3 gpm depending on the model you choose. (**CSV125-1/CSV125-1** or **CSV125-3/CSV125-3**). We recommend a 1 gpm bypass for 2HP and smaller and a 3 gpm bypass for 3HP and 5HP. If you demand more than your pump can provide at the pressure the valve is trying to hold, the valve will stop actuating at all and open fully. Your system pressure will become whatever pressure the pump can build at that point.

When there is no longer any demand on the system, water will begin to go into the pressure tank and the system pressure will begin to rise. The pressure tank will then refill slowly at the valve minimum control rate of 1 gpm or 3 gpm (not your full pump rate) until it reaches shut off pressure. Keep this in mind when choosing your pressure tank as this function allows for a much smaller pressure tank to protect your pumping system than you would be able to use on a standard system without the **CSV** valve controlling the pump. Motor manufacturers recommend a minimum 1 minute of run time any time your pump is called to come on. The time it takes to refill your pressure tank will guarantee that run time regardless of how you use water.

When water is again demanded, the pressure tank will empty causing the system pressure to reach cut in pressure and the pressure switch will start the pump.  
*NOTE: Pressure switch shut off pressure must always be set higher than the pressure regulated by the **CSV**. Maximum pump shut off pressure or total head cannot be more than 150 PSI. It is very important that this model not be installed in a bind or pulled apart at the center as it can bend or separate over time and begin to squirt water.*

The **CSV125/CSV125** is a vented valve (it vents air when it actuates). Over time, (how long usually depends on water quality) the air chamber can fill with water and the **CSV125/CSV125** can begin to vent that water to atmosphere. (That drip is a function of the valve actuating and not a leak) The valve will function correctly whether it is venting air or water. This valve can also be installed in the well casing and can support weights of up to 500 lbs of pump/pipe. If venting of water "weeping" is not acceptable for your application, an alternative model for most of the same applications would be the **CSV1A** or **CSV2W**.

**Note: In multiple pump applications, each pump must have its own valve.**



# -Model- CSV125 / CSVS125

## Specifications

### Materials

- \* Engineer-grade thermoplastic or 304 Stainless Steel
- \* Stainless steel compression spring
- \* Buna N diaphragm

### Pressure - Temperature

- \* Max water temp 90 degrees F
- \* Max shut off pressure 150 PSI
- \* Preset settings 30,40,50,60 PSI
- \* SS version 50, 60 PSI only

### Features

- \* 1-30 GPM or 3-50 GPM
- \* Maintains constant outlet pressure
- \* Tank refill rate 1 or 3 gpm
- \* CSV125/CSVS125 can be installed in the well casing for up to 500 lbs of pump/pipe weight for the CSV125 model or 1000 lbs for CSVS125 model.

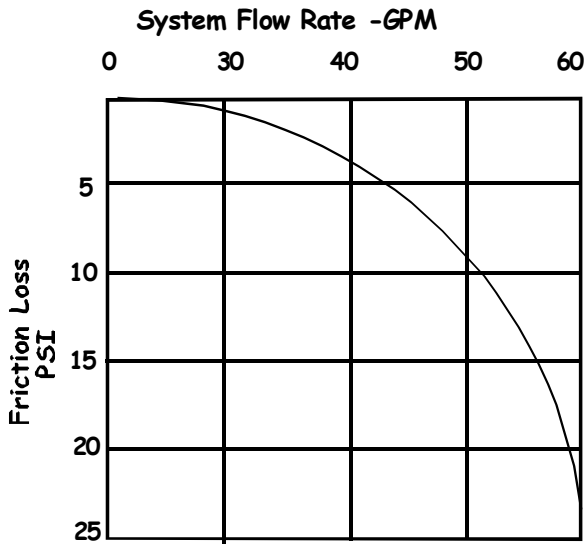
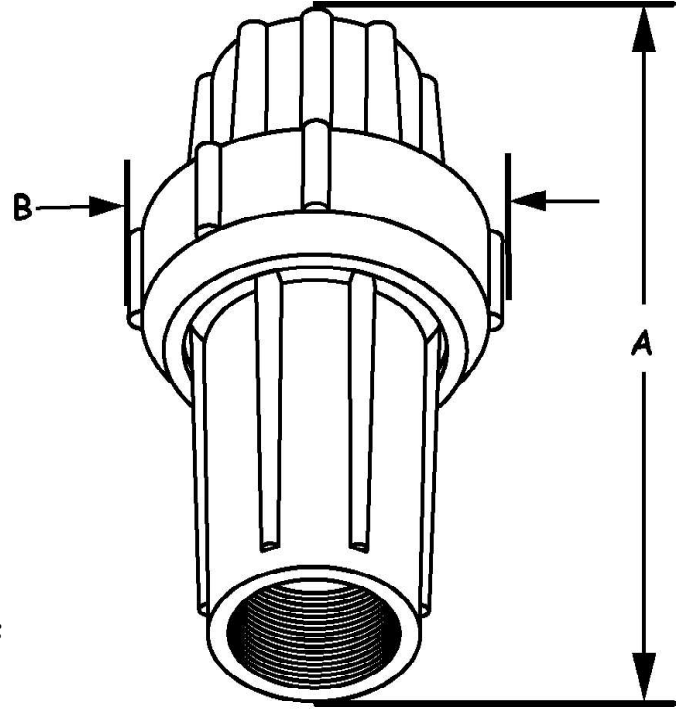

### CSV125 Dimensions

<u>Size</u>	<u>A</u>	<u>B</u>	<u>Wt</u>
1 1/4" NPT	5 7/8"	3 1/2"	15 oz

### CSVS125 Dimensions

<u>Size</u>	<u>A</u>	<u>B</u>	<u>Wt</u>
1 1/4" NPT	5 7/8"	3 1/4 "	3.5 lbs



# -Model- CSV1A / CSV2W1.25



**CSV1A**



**CSV2W1.25T**



# - Model -

## CSV1A / CSV2W1.25

The Cycle Stop Valve model CSV1A, and CSV2W are pump control valves that automatically adjust pump output to match your variable demands. This product creates back pressure, that is how it works. Back pressure is determined by the pump you are using. Be sure your piping between the pump and the Cycle Stop Valve is rated for that pressure.

As your demands vary, the CSV reacts to changes in pressure and opens and closes accordingly. This enables it to hold a constant pressure as long as your demand is more than the minimum control flow of 1 or 5 gpm depending on the model you choose (1A-1gpm, 2W-1 or 5gpm). These models (T shaped valves) also have a reduced pressure fall off function. (See charts on pages 12,13,and 14)

If you demand more than your pump can provide at the pressure the valve is trying to hold, the valve will stop actuating at all and open fully. Your system pressure will become whatever pressure the pump can build at that point.

When there is no longer any demand on the system, water will begin to go into the pressure tank and the system pressure will begin to rise. The pressure tank will then refill slowly at the valve minimum control rate of 1 gpm or 5 gpm (not your full pump rate) until it reaches shut off pressure. Keep this in mind when choosing your pressure tank as this function allows for a much smaller pressure tank to protect your pumping system than you would be able to use on a standard system without the CSV valve controlling the pump. Motor manufacturers recommend a minimum 1 minute of run time any time your pump is called to come on. The time it takes to refill your pressure tank will guarantee that run time regardless of how you use water.

When water is again demanded, the pressure tank will empty causing the system pressure to reach cut in pressure and the pressure switch will start the pump. *NOTE: Pressure switch shut off pressure must always be set higher than the pressure regulated by the CSV.*

Model CSV1A is dual threaded and is available in 1" female NPT and 1 1/4" male NPT. The "1A" model is certified by WQA to NSF/ANSI 61-372 standards. It is adjustable from 15-150 PSI (150-300 PSI available). The "2W" model is available in 1 1/4" female NPT thread and has pressure settings available from 25-75 PSI or 50-120 PSI. Difference in pressure between inlet pressure and outlet pressure cannot be more than 125 PSI. Note: In multiple pump applications, each pump must have its own valve.

# -Model-CSV1A Specifications

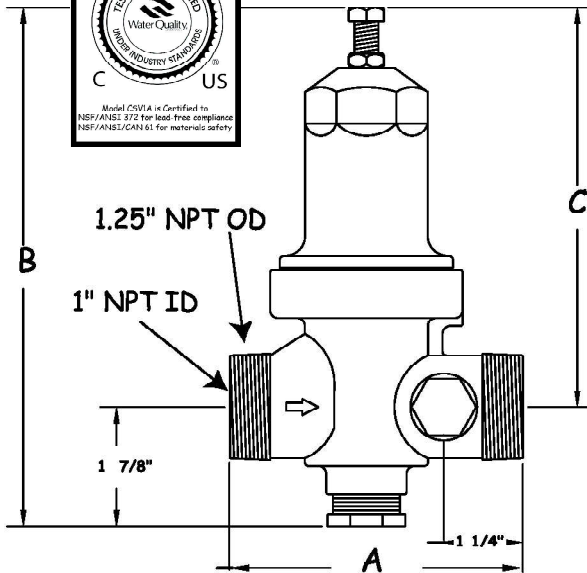

## Materials

- \* 304 stainless steel
- \* Molded thermoplastic spring cage
- \* EPDM with dacron cloth insert diaphragm
- \* Replaceable acetal cartridge

## Pressure - Temperature

- \* Max temperature 100 F
- \* Max shut off head 400 psi
- \* Adjustable pressure 15-150 psi  
w/150-300 psi available
- \* Max differential pressure 125 psi

## Features

- \* 1-25 gpm flow range
- \* Variable flow with reduced pressure
- \* Tank fill rate 1 gpm
- \* All internal parts corrosion resistant and included in a drop in cartridge
- \* 1" female NPT thread
- \* 1 1/4" male pipe thread
- \* 2) 1/2" and 1) 3/4" additional manifold ports

Dimensions				Wt
Size	A	B	C	
1"	4 9/16"	8 1/8"	6 1/4"	4lbs

Reduced pressure fall off is a function of every pressure reducing style valve including the CSV1A model. (This is not a friction loss.) The chart below shows the reduction in pressure depending on flow or demand. For example, a demand of 10 gpm would create a reduced pressure fall off of 5 PSI. This number should be kept in mind when you set your Cycle Stop valve pressure...(for example...if pressure required at 10 gpm is 50 PSI...with demand at 2 gpm, set the Cycle Stop at 55 PSI to adjust for the 5 PSI reduced pressure you will experience at 10 gpm).

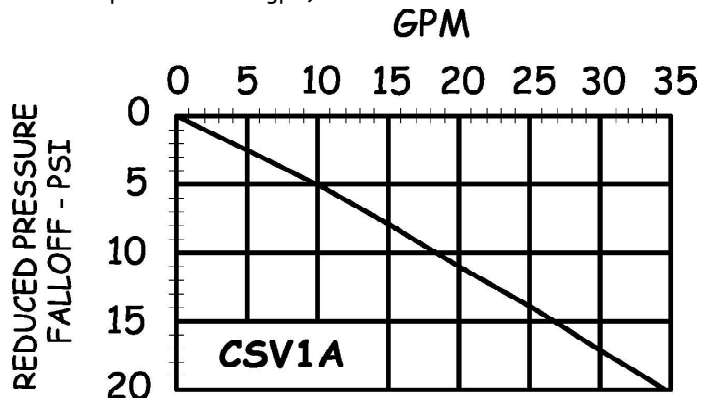
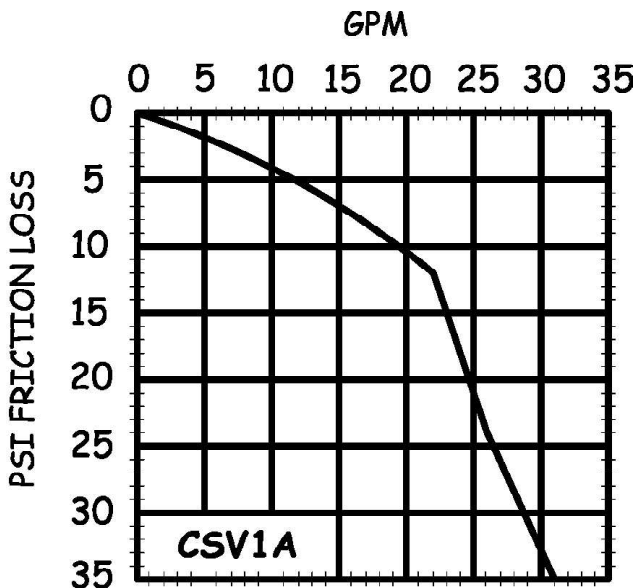



# - Model - CSV2W Specifications

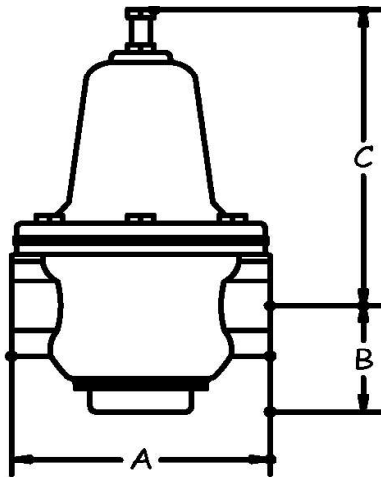

## Materials

- \* Bronze body standard  
No lead available
- \* Renewable stainless steel seat
- \* Reinforced buna N diaphragm
- \* Buna-N valve disc

## Pressure - Temperature

- \* Max temperature 160 F
- \* Max shut off head 300 psi
- \* Pressure adjustment ranges  
25-75 psi or 50-120 psi
- \* Max differential pressure 125 psi

Dimensions						Wt	
Size	A		B		C	lbs	
	In	MM	In	MM	In	MM	
1 1/4"	5	127	2 3/4	70	6 3/4	172	10

## Features

- \* 5-50 gpm
- \* Variable flow with reduced pressure
- \* Tank fill rate approx 5 gpm

Reduced pressure fall off is a function of every pressure reducing style valve including the CSV2W model. (This is not friction loss.) The chart below shows the reduction in pressure depending on flow or demand. For example, a demand of 50 gpm would create a reduced pressure fall off of 10 PSI. This number should be kept in mind when you set your Cycle Stop valve pressure...(for example...if pressure required at 10 gpm is 50 PSI...with demand at 6-8 gpm, set the Cycle Stop at 60 PSI to adjust for the 10 PSI reduced pressure you will experience at 50 gpm).

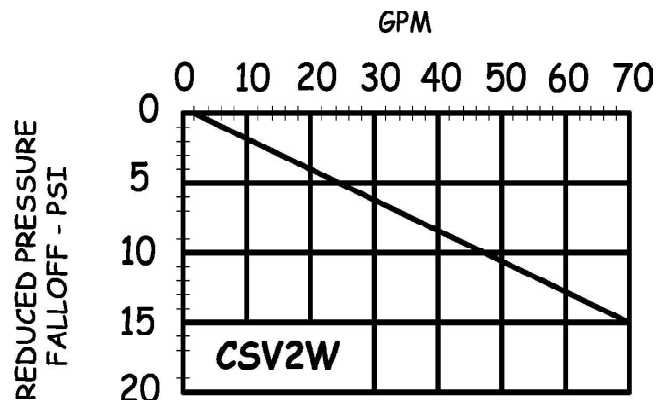
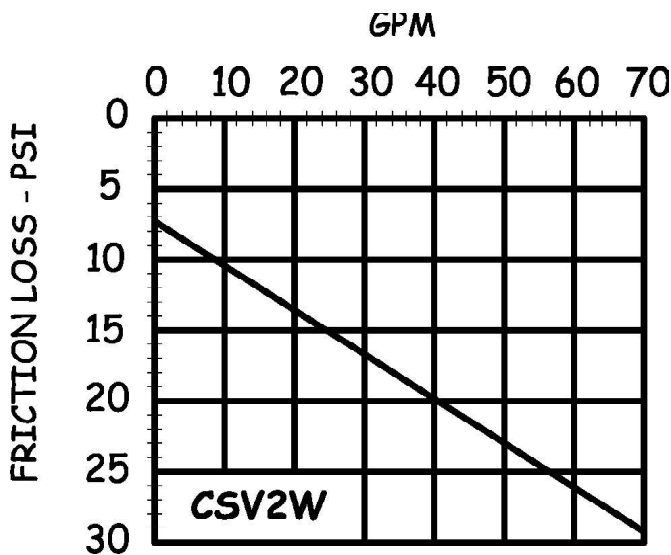

# Application Information

## Model CSV125, CSVS125, CSV1A, and CSV2W



- A) Pump
- B) Motor
- C) Check valve
- D) Cycle Stop Valve
- E) Pressure tank
- F) Pressure relief valve
- G) Pressure gauge
- H) Isolation valve
- P) Pressure switch

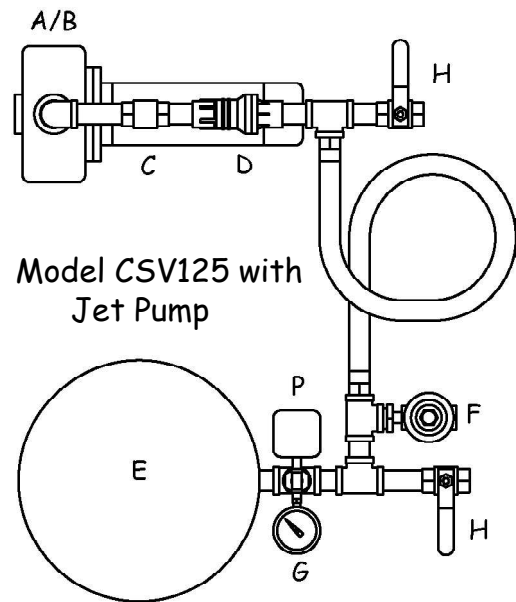
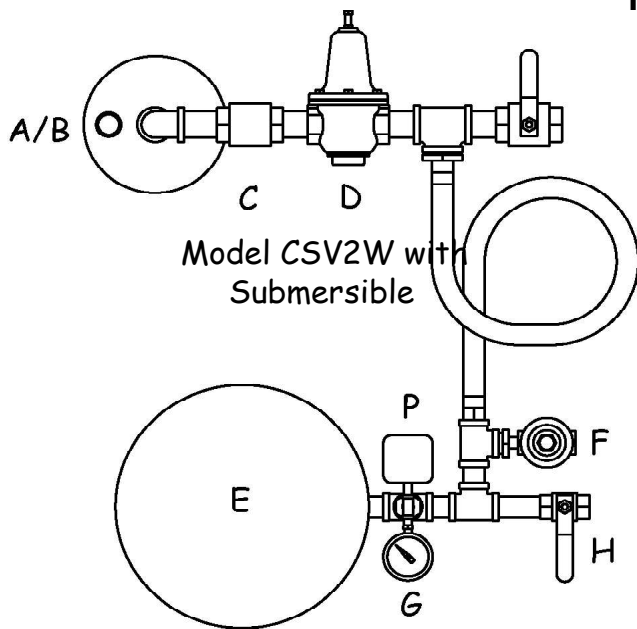
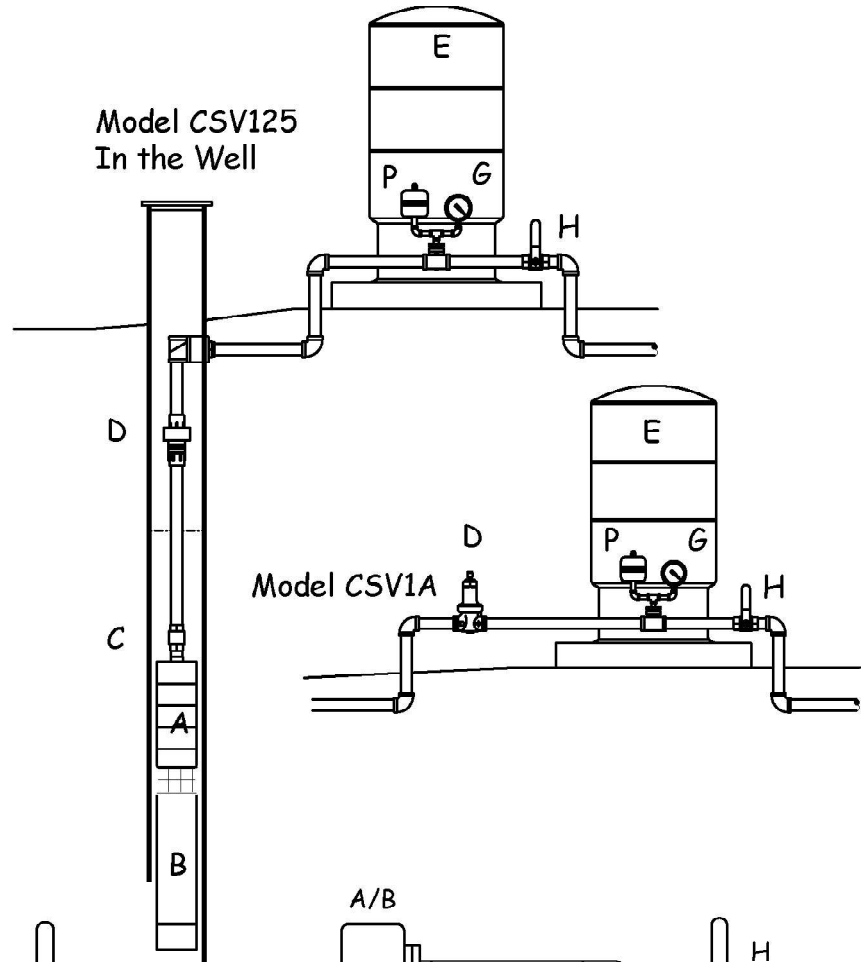



# -Model- CSV3 A or B

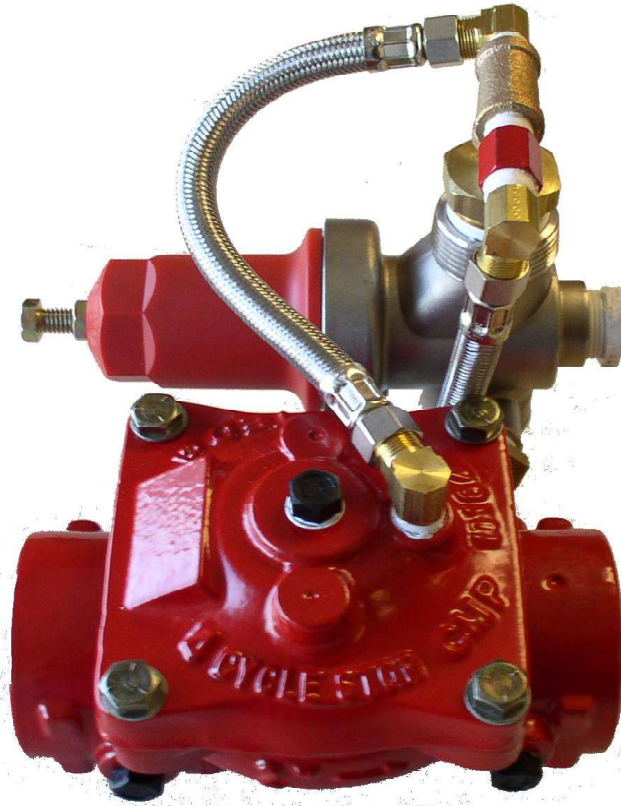

# -Model- CSV3 A or B



The Cycle Stop Valve model CSV3 A or B is a pump control valve that automatically adjust pump output to match your variable demands. This product creates back pressure, that is how it works. Back pressure is determined by the pump you are using. Be sure your piping between the pump and the Cycle Stop Valve is rated for that pressure.

As your demands vary, the CSV reacts to changes in pressure and opens and closes accordingly. This enables it to hold a constant pressure as long as your demand is more than the minimum control flow of 5 gpm.

If you demand more than your pump can provide at the pressure the valve is trying to hold, the valve will stop actuating at all and open fully. Your system pressure will become whatever pressure the pump can build at that point.

When there is no longer any demand on the system, water will begin to go into the pressure tank and the system pressure will begin to rise. The pressure tank will then refill slowly at the valve minimum control rate of 5 gpm (not your full pump rate) until it reaches shut off pressure. Keep this in mind when choosing your pressure tank as this function allows for a much smaller pressure tank to protect your pumping system than you would be able to use on a standard system without the CSV valve controlling the pump. Motor manufacturers recommend a minimum 1 minute of run time any time your pump is called to come on. The time it takes to refill your pressure tank will guarantee that run time regardless of how you use water.

When water is again demanded, the pressure tank will empty causing the system pressure to reach cut in pressure and the pressure switch will start the pump. *NOTE: Pressure switch shut off pressure must always be set higher than the pressure regulated by the CSV.*

The CYCLE STOP VALVE models CSV3 A or B are single chamber diaphragm operated valves. Model CSV3 A / B valves are adjustable between 15-150 PSI. Difference in pressure between inlet pressure and outlet pressure cannot be more than 125 PSI. Note: In multiple pump applications, each pump must have its own valve.



# -Model- CSV3 A or B Principle of Operation

The CSV3 Model A or B is a single chamber hydraulically operated automatic valve which combines the simplicity and reliability of a diaphragm valve with control capabilities of a pilot operated self acting regulator.

The diaphragm is a single unit comprised of three separate and distinct parts; the flexing element, the guiding element and the sealing element. The flexing element is designed solely as a diaphragm. The sealing element needs only to seal to minimum flow. Additionally, the body design fully supports the guiding element of the diaphragm/seal, which because of its design and hydraulic force, expands against the body support as it closes.

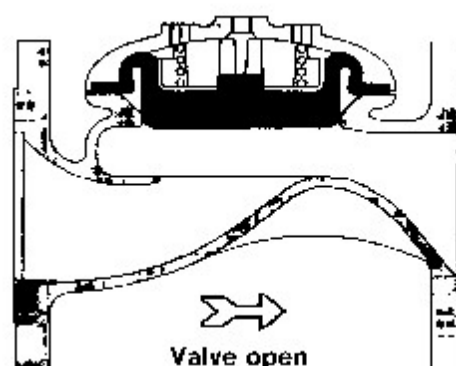
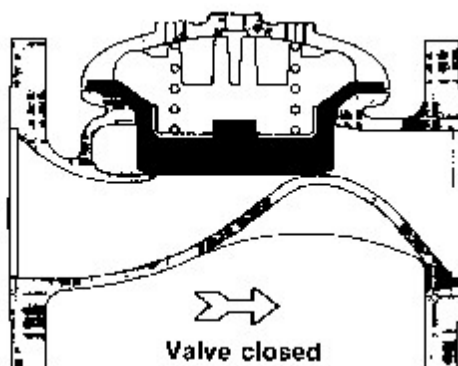



# -Model- CSV3A Specifications

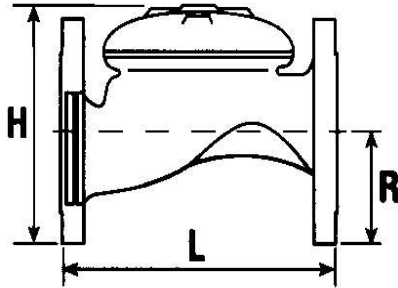

### Materials

- \* Body and cover; polyester coated ductile iron
- \* Diaphragm retainer and spring: stainless steel
- \* Diaphragm: EPDM
- \* Control piping: braided stainless steel
- \* Control fittings: brass and 304 stainless steel

### Features

- \* Sizes 2" threaded, 3" threaded or flanged, and 4" flanged
- \* Flow ranges available between 5-5000 gpm
- \* Maintains constant outlet pressure
- \* Single chamber diaphragm operated
- \* Single one moving part design

### Pressure - Temperature

- \* Max temperature 100 degrees F
- \* Max shutoff head 400 PSI
- \* Pressure ranges 15-150 PSI
- 150-300 PSI available
- \* Max differential pressure 200 PSI
- \* Min friction loss 7 PSI

Size	2"	3"	3"	4"
Type	Threaded	Threaded	Flanged	Flanged
L	6 7/8	11 1/2	9 13/16	12 5/8
H	4 15/16	6 5-16	8 1/16	9 1/2
Width	4 3/4	6 7/8	7 7/8	8 3/4
R	1 1/2	2 3/16	3 15/16	4 7/16
Weight	18	35	45	66

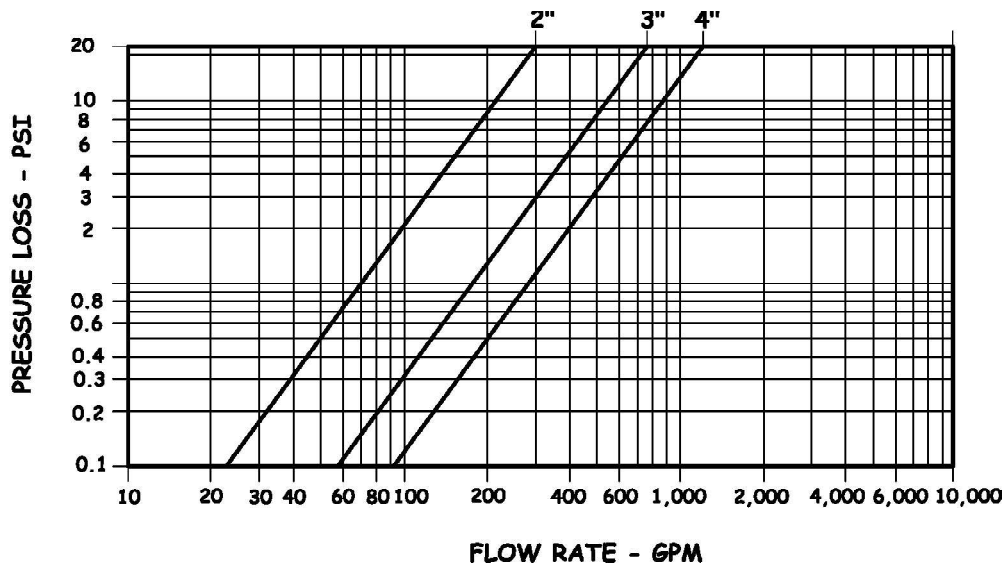



# -Model- CSV3B Specifications

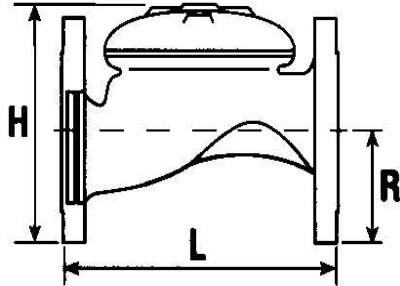

### Materials

- \* Body and cover; polyester coated cast iron
- \* Diaphragm retainer and spring: stainless steel
- \* Diaphragm: natural rubber, nylon fabric reinforced (Options -Nitrile, Buna N, EPDM)\*
- \* Control piping: braided stainless steel
- \* Control fittings: brass and 304 stainless steel

### Features

- \* Sizes 2" threaded, 3" threaded or flanged, 4", 6", 8", 10" and 12" flanged
- \* Flow ranges available between 5-5000 gpm
- \* Maintains constant outlet pressure
- \* Single chamber diaphragm operated
- \* Single one moving part design

### Pressure - Temperature

- \* Max temperature 100 degrees F
- \* Max shutoff head 225 PSI
- \* Pressure ranges 15-150 PSI  
150-225 PSI available
- \* Max differential pressure 125 PSI
- \* Min friction loss 14 PSI

Size	4"	6"	8"	10"	12"
Type	Flanged	Flanged	Flanged	Flanged	Flanged
L	12 5/8	16 5/16	19 11/16	23 13/16	28 1/2
H	9 1/2	13 5/16	16 15/16	18 1/8	25
Width	8 3/4	12 3/8	15 3/8	15 15/16	22 7/8
R	4 7/16	5 1/2	6 11/16	7 15/16	9 7/16
Weight	65	150	309	329	680

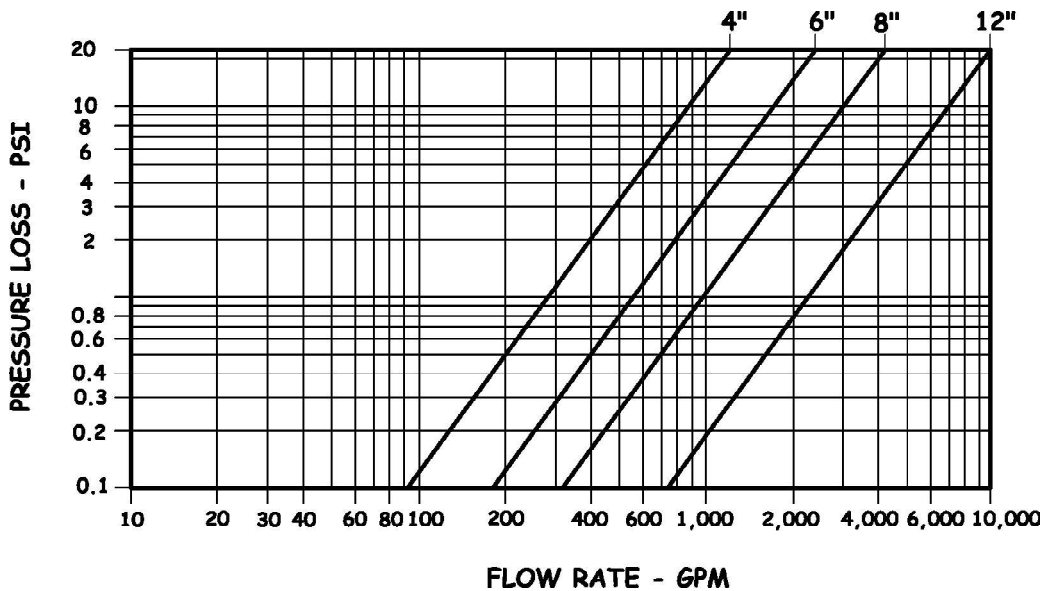

# -Model- CSV3 A or B Operating Data

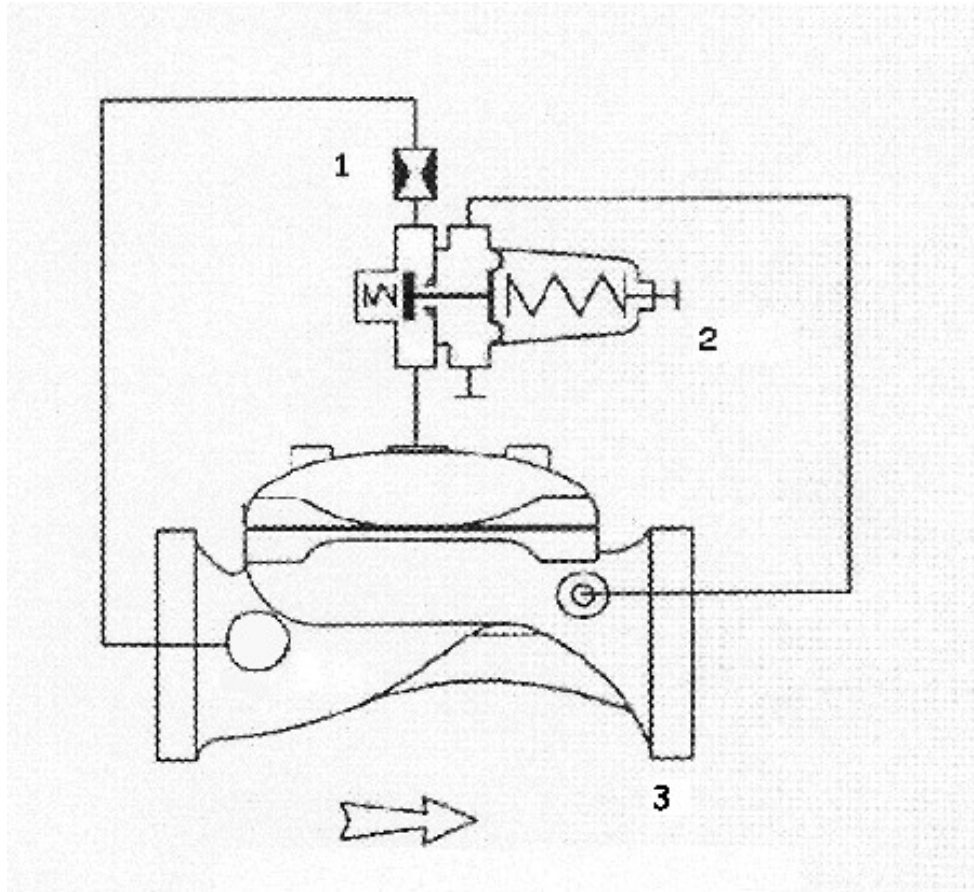

Item#	Basic Components	Qty
1	Orifice	1
2	Pressure Reducing Pilot	1
3	Main Valve Body	1

## Description:

The valve maintains a constant downstream pressure regardless of demand or changing upstream pressure. The reducing pilot senses downstream pressure and modulates the main valve to maintain the setpoint. When downstream pressure falls below the setting of the reducing pilot, the pilot opens allowing the main valve to open to increase pressure to the setpoint. When downstream pressure rises above the setting of the reducing pilot, the pilot closes causing the main valve to throttle toward a closed position to maintain the setpoint. When there is no longer any demand on the system, the main body seats to a minimum flow.



# -Model-CSV3R

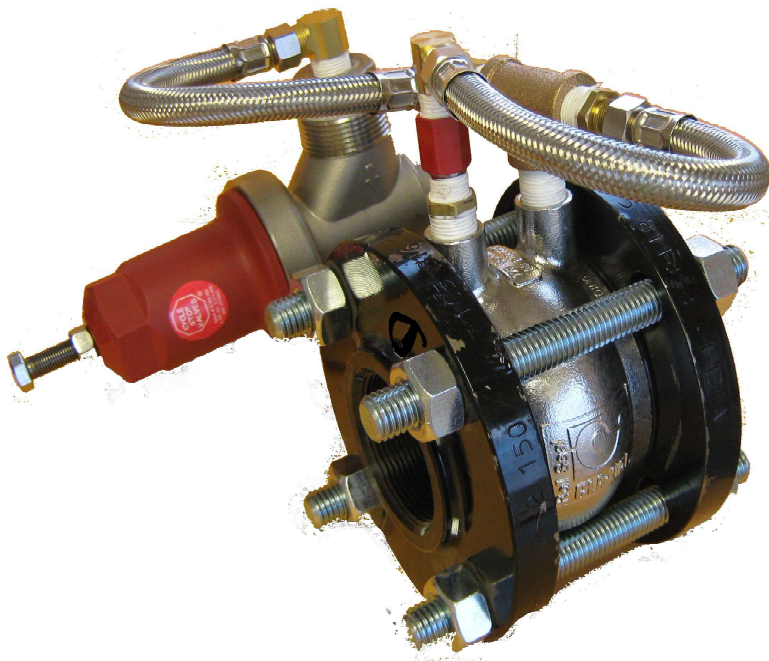

# -Model- CSV3R



The CYCLE STOP VALVE model CSV3R is a pump control valve that automatically adjusts pump output to match variable flow requirements. This product creates back pressure, that is how it works. Back pressure is determined by the pump you are using. Be sure your piping between the pump and the Cycle Stop Valve is rated for that pressure.

As your demands vary, the CSV reacts to changes in pressure and opens and closes accordingly. This enables it to hold a constant pressure as long as your demand is more than the minimum control flow of 5 gpm.

If you demand more than your pump can provide at the pressure the valve is trying to hold, the valve will stop actuating at all and open fully. Your system pressure will become whatever pressure the pump can build at that point.

When there is no longer any demand on the system, water will begin to go into the pressure tank and the system pressure will begin to rise. The pressure tank will then refill slowly at the valve minimum control rate of 5 gpm (not your full pump rate) until it reaches shut off pressure. Keep this in mind when choosing your pressure tank as this function allows for a much smaller pressure tank to protect your pumping system than you would be able to use on a standard system without the CSV valve controlling the pump. Motor manufacturers recommend a minimum 1 minute of run time any time your pump is called to come on. The time it takes to refill your pressure tank will guarantee that run time regardless of how you use water.

When water is again demanded, the pressure tank will empty causing the system pressure to reach cut in pressure and the pressure switch will start the pump. *NOTE: Pressure switch shut off pressure must always be set higher than the pressure regulated by the CSV.* This model will not tolerate trash being pumped through it and needs to be used in clean water only applications.

Difference in pressure between inlet pressure and outlet pressure cannot be more than 125 PSI. Note: In multiple pump applications, each pump must have its own valve.

The CYCLE STOP VALVE model CSV3R is available in 2" to 12" with flow rates available from 5 gpm to 5000 gpm. Sizes 2" through 4" are available in a wafer type flanged mode and sizes 6" through 12" are only available in a flanged model. They are adjustable from 15-150 PSI ( 100-300 PSI available).



# -Model- CSV3R Principle of Operation

The CSV3 model R is a hydraulically operated pump control valve used to adjust to variable flow needs by means of a flexible control element, the liner.

The basic valve consists of only two parts: a one piece, investment cast body and an elastomeric liner. The valve body is constructed with internal ribs and slots forming grillwork which surrounds the liner to provide support. A normally closed type valve is formed by the installed liner which covers the grillwork and seats against the raised seating surface in the valve body.

Upstream pressure actuates the valve to produce valve opening by rolling the liner off the seating surface and the slotted grillwork. The valve is controlled by downstream pressure as the pressure supplied to the control chamber is varied by an external pilot system or CSV1A.

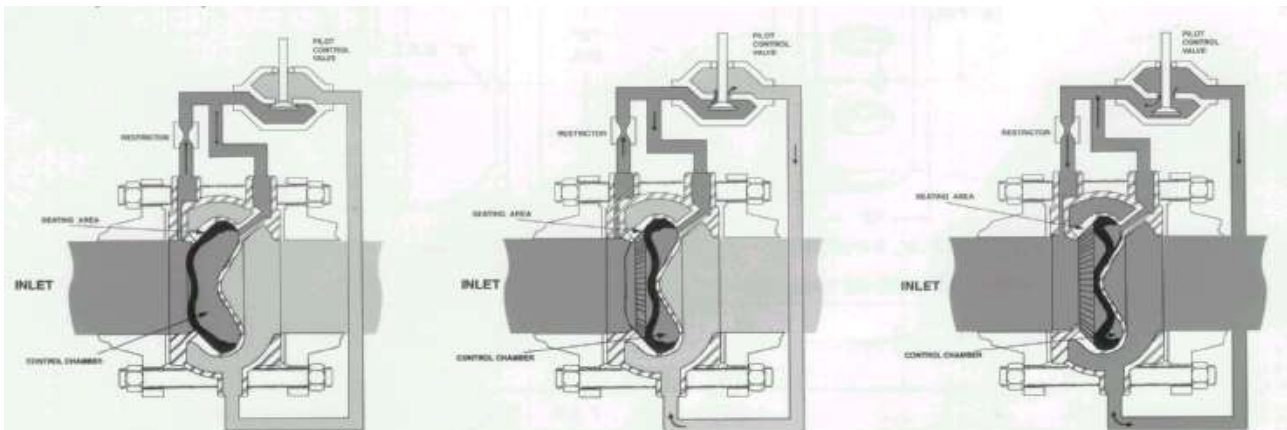

## Closed Position

Upstream pressure is introduced to the control chamber through the control piping and restrictor. When the pilot is closed, full inlet pressure is supplied to the control chamber, thus balancing the force developed by inlet pressure acting on the upstream face on the liner. Under these conditions, the liner remains in the fully closed position allowing minimum pump cooling flow passed the seat. Since the operating pressure in the control chamber is greater than the outlet pressure, an additional closing force is developed across the liner, pressing the liner against the surrounding slotted grillwork area and seating surface.

## Partially Open Position

As loading pressure is lowered slightly below inlet pressure, the central portion of the liner is forced to invert and come to rest against the tip of the control chamber cavity. Reducing the loading pressure further (but still higher than outlet pressure) causes the liner to drape over the cone shaped portion of the control chamber cavity. This action causes the outer section of the liner to roll off the seating surface and a portion of the grillwork to partially open the valve.

## Fully Open Position

The valve is fully opened when loading pressure is sufficiently reduced to allow the liner to roll back completely and expose the full slot area. Restoring loading pressure reverses the liner rolling action to return the liner to the fully closed position.

# -Model- CSV3R Specifications



## Materials

- \* Body: 18-8 (304L) stainless steel\*
- \* Liner: Natural rubber, 65 durometer (standard)  
Viton, EPDM, Nitrile, Silicone available
- \* Liner Retainer: 18-8 (304 stainless steel)\*
- \* Pilot body, Spring cover: 304 stainless steel,  
molded thermoplastic
- \* Control piping: braided stainless steel
- \* Control fittings: brass and 304 stainless steel

## Pressure - Temperature

- \* Temperature range 32-100 degrees F
- \* Max shut off head 300 psi
- \* Max differential psi 125 psi  
Note: Higher differentials possible with  
this model, call factory for more info
- \* Min friction loss 14 psi
- \* Pressure adjustment range 15-150 psi  
(150-300 psi available)

## Features

- \* Sizes 2,3, and 4 wafer style, 6" and larger flanged
- ~wafer fits ANSI B16.5 class 125,150,250,300 flanges
- ~flanged fits ANSI B16.5 class 150 (fits class 125) or  
ANSI B16.5 class 300 (fits class 250)
- \* Flow ranges available between 5 gpm to 5000 gpm
- \* Maintains constant outlet pressure
- \* Compact lightweight design
- \* Compatible with ANSI 125,150,250, or 300 class  
flanges
- \* Two part design

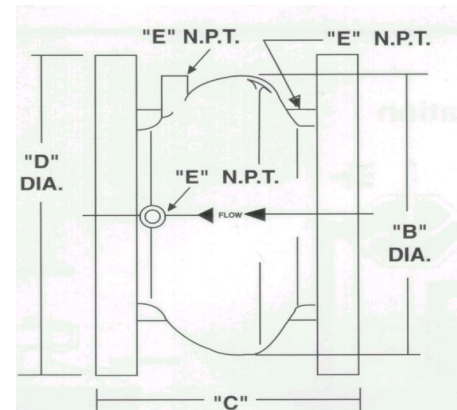
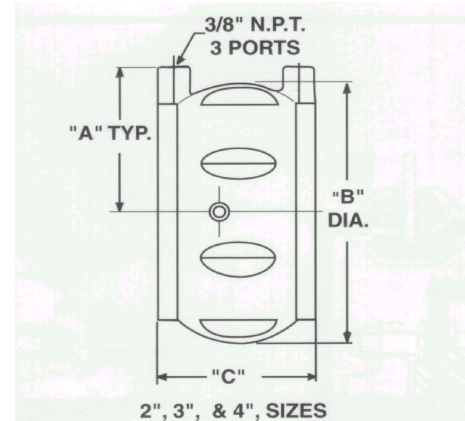

Valve Size in Inches	A	B	C	D Ansi 150	D Ansi 300	E Ports	Weight #150	Weight #300
2	2 7/8	4 3/8	2 1/2	-	-	-	15	15
3	3 9/16	5 7/8	3 1/4	-	-	-	20	20
4	4 1/8	7 3/8	4	-	-	-	29	29
6	-	10 7/8	9	11	12 1/2	3/8	90	90
8	-	14 3/8	11	13 1/2	15	3/8	115	155
10	-	18	13	16	17 1/2	1/2	190	250
12	-	21 5/8	15 1/4	19	20 1/2	1/2	290	375



# -Model- CSV3R Flow Chart

For Water Application (Specific Gravity 1.00)

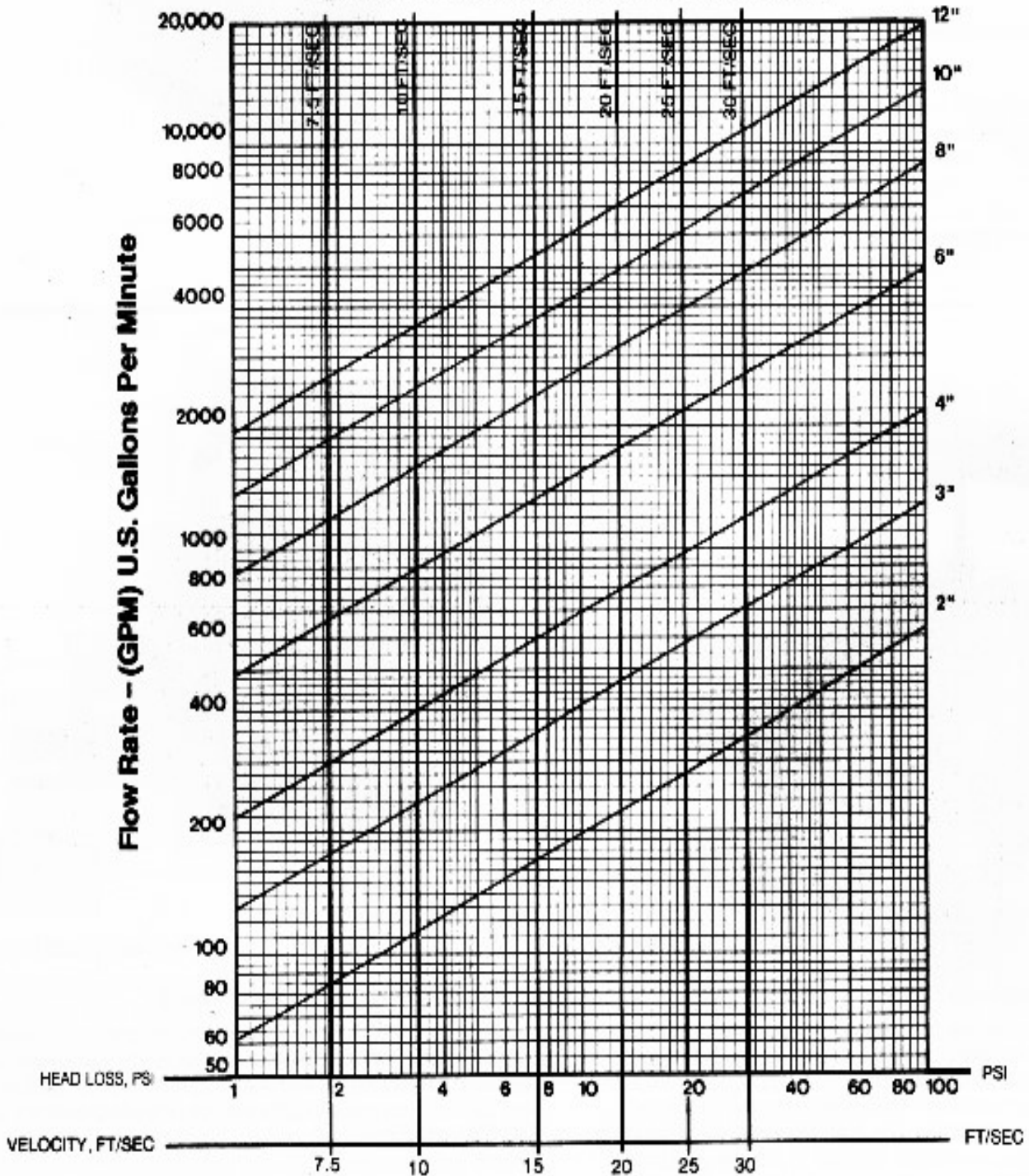



# -Model- CSV3R Operating Data

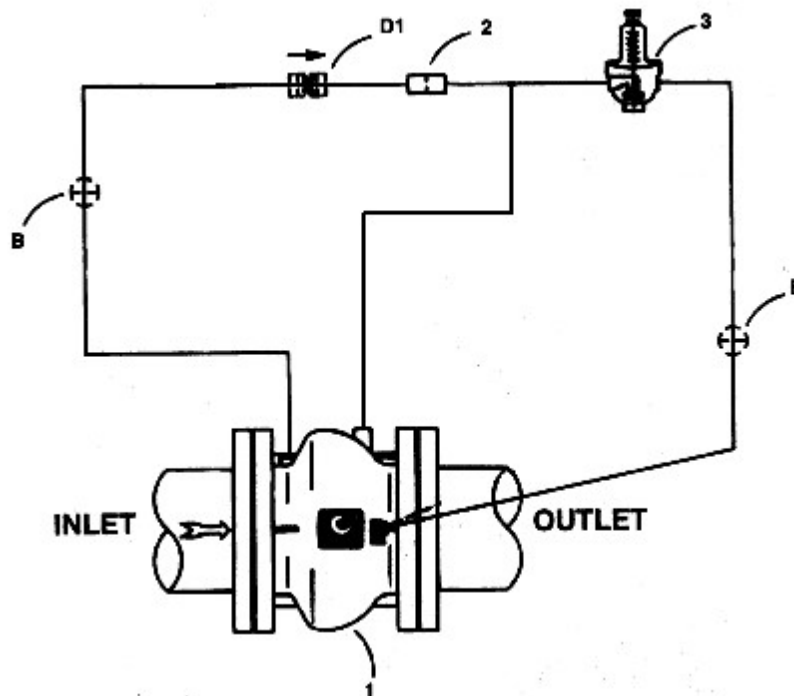

Item#	Basic Components	Qty
1	Main Valve	1
2	restriction fitting	1
3	CSV1A pressure reducing control	1

### Pressure reducing feature:

Pressure reducing control (3) is normally open control that senses main valve outlet pressure changes. An increase in outlet pressure tends to close control (3) and decrease in outlet pressure tends to open control (3). This causes main valve loading chamber pressure to vary and the main valve modulates (opens and closes) maintaining a relatively constant outlet pressure. Pressure reducing control (3) adjustment: Turn the adjusting screw clockwise to increase the setting.



# Application Information Model CSV3

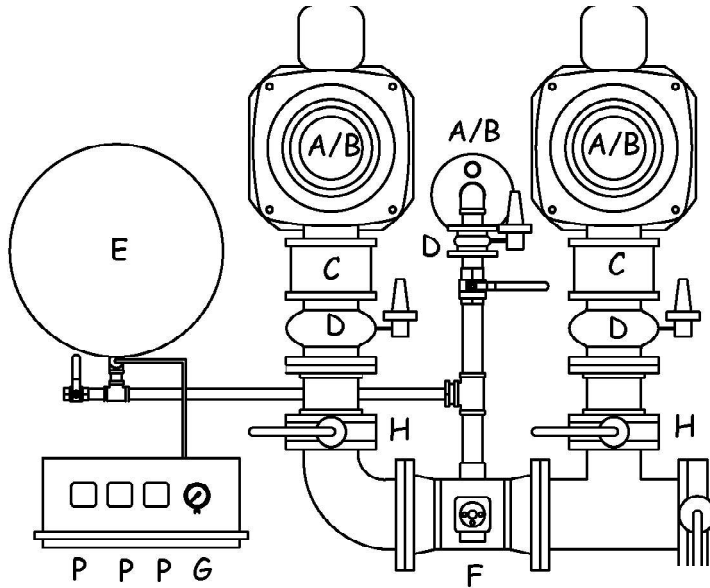

Model CSV3R with  
Turbine Pumps

- A) Pump
- B) Motor
- C) Check valve
- D) Cycle Stop Valve
- E) Pressure tank
- F) Pressure relief valve
- G) Pressure gauge
- H) Isolation valve
- P) Pressure switch

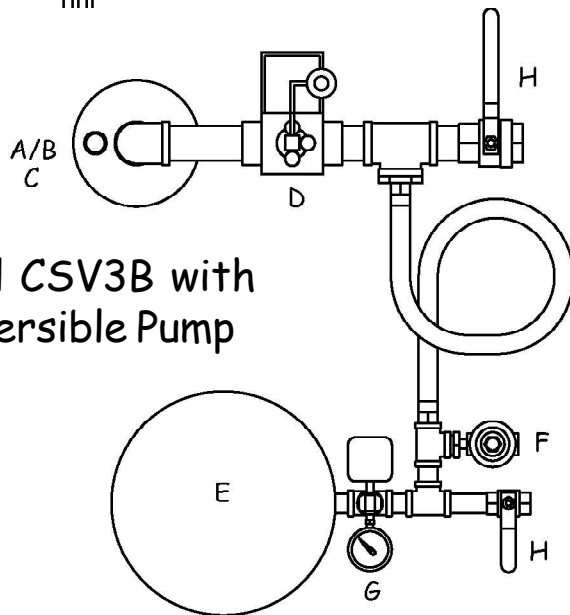

Model CSV3B with  
Submersible Pump

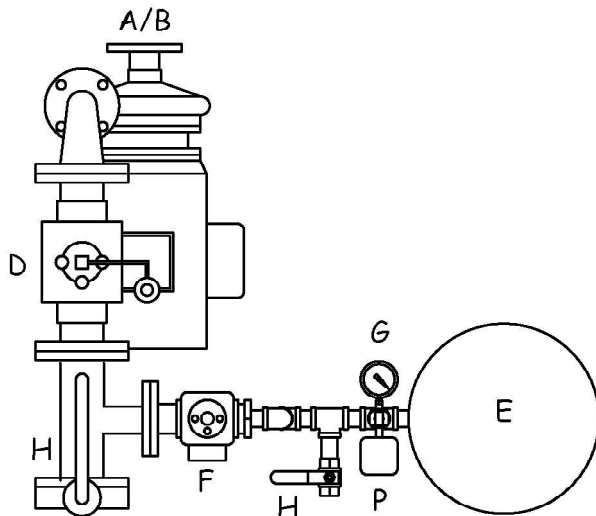

Model CSV3B with  
Centrifugal Pump

# -Model- CSV3A/B and CSV3R Pilot Specifications

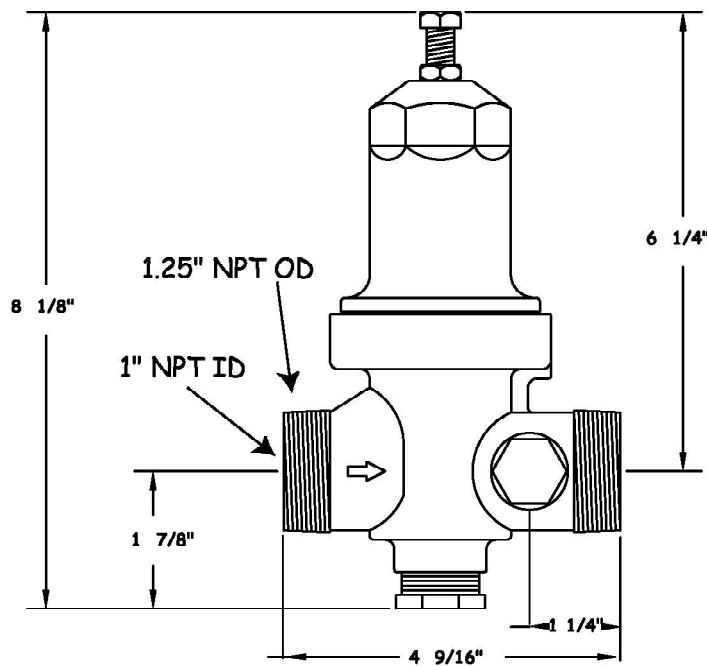

## Materials

- \* 304 stainless steel
- \* Molded thermoplastic spring cage
- \* NSF grade Buna N diaphragm
- \* Replaceable acetal cartridge

## Pressure - Temperature

- \* Max temperature 100 F
- \* Max shut off head 400 psi
- \* Adjustable pressure 15-150 psi  
150-300 psi available

## Features

- \* Pilot control valves for Models CSV3B and CSV3R.
- \* Direct acting, diaphragm type regulator
- \* Used to adjust downstream pressure

# pside-kick®

Complete Constant  
Pressure  
Pump Control Kits



Cycle Stop Valves announces the newest addition to our "Constant psi" family.

The *pside-kick*® is the most "user friendly" complete constant pressure pump control kit available. Use in systems with up to 25 gpm capability and a wide range of flow demands. Eliminates the need for large pressure tanks.

The *pside-kick*® is also a reliable, economical replacement for variable speed controllers. (including the Grundfos® CU301 or Franklin® Monodrive and switch for Subdrive®)

## All you add is the pump!



**Model PK1A**

### Includes:

- 1) Cycle Stop Valve model CSV1A preset to 50 PSI
- 1) 4.4 gallon pressure tank
- 1) Wall mount kit
- 1) 1/2" SS Pressure relief valve
- 1) 1/4" SS tee
- 2) 1/4" X close SS nipple
- 1) 1/2" X 1/4" SS hex reducer
- 1) 1/4" X 1/4" snubber
- 1) 1/4" pressure gauge
- 1) 40/60 pressure switch
- 1) roll teflon tape
- 1) Installation instructions

# Typical Applications

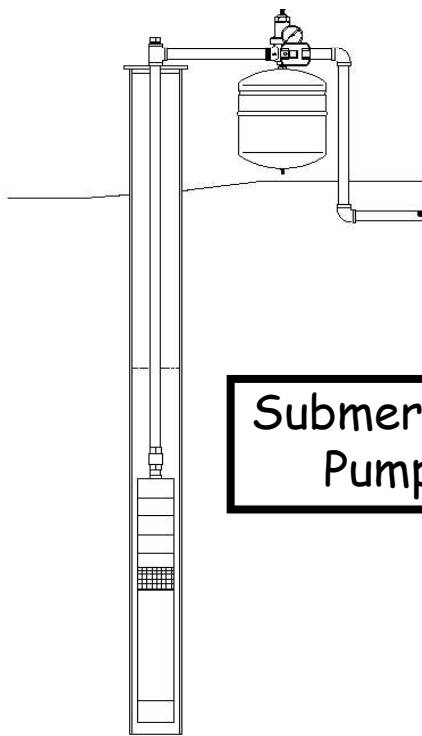

Submersible Pump

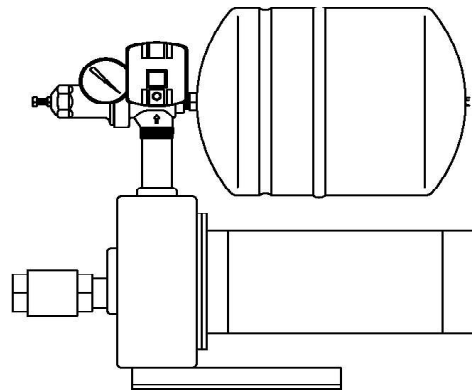

Jet Pump

Pipe/fittings installed before the *pside-kick*® must be pressure rated to handle the maximum head or shut off pressure that your pump can build. If you have leaks or extended water usage of less than 1 gpm, adding an additional pressure tank in your system is recommended.

**The *pside-kick*® controls many different pumps set at various depths and pressures.**

The table on the following page is the majority of standard domestic pump model sizes that are available and the minimum/maximum water levels (or depth to water) in your well that are required for those models to work with this *pside-kick*®. It has been preset to work best within these parameters. (Although preset, this is an adjustable product. If your system does not fall exactly within these ranges, please contact manufacturer for adjustment suggestions to fit your specific needs.)

To use the table on the following page, choose your GPM series pump and find the depth or distance from the surface to water information that applies. As long as the water level in your well is not less than the minimum level and not more than the maximum level shown in the table, the *pside-kick*® will work as designed.



# Compatible pump types and sizes

Depth to water Minimum level	Depth to water Maximum level	
<b>Pump Type and Size</b>		
<b>Submersible Pumps</b>		
<i>(Note...These are water levels...not pump depth settings)</i>		
<b>5 GPM Series</b>		
1/2 HP	0'	210'
3/4 HP	130'	350'
1 HP	275'	460'
1.5 HP	500'	690'
2 HP	675'	870'
<b>7 GPM Series</b>		
1/2 HP	0'	115'
3/4 HP	0'	215'
1 HP	125'	344'
1.5 HP	275'	495'
2 HP	550'	780'
3 HP	800'	1015'
<b>10 GPM Series</b>		
1/2 HP	0'	40'
3/4 HP	0'	130'
1 HP	0'	205'
1.5 HP	150'	380'
2 HP	250'	475'
3 HP	475'	700'
<b>13 GPM Series</b>		
1/2 HP	0'	10'
3/4 HP	0'	60'
1 HP	0'	160'
1.5 HP	0'	220'
2 HP	135'	380'
3 HP	350'	600'
<b>15 GPM Series</b>		
1/2 HP	0'	10'
3/4 HP	0'	40'
1 HP	0'	140'
1.5 HP	0'	200'
2 HP	175'	360'
3 HP	355'	580'
<b>16 GPM Series</b>		
3/4 HP	0'	60'
1 HP	0'	120'
1.5 HP	0'	20'
2 HP	140'	360'
3 HP	315'	540'

Depth to water Minimum level	Depth to water Maximum level	
<b>Pump Type and Size</b>		
<b>Submersible Pumps</b>		
<b>18 GPM Series</b>		
3/4 HP	0'	10'
1 HP	0'	70'
1.5 HP	0'	170'
2 HP	50'	260'
3 HP	200'	400'
<b>20 GPM Series</b>		
3/4 HP	0'	10'
1 HP	0'	70'
1.5 HP	0'	140'
2 HP	10'	240'
3 HP	200'	420'
<b>22 GPM Series</b>		
1 HP	0'	20'
1.5 HP	0'	110'
2 HP	0'	180'
<b>25 GPM Series</b>		
1 HP	0'	30'
1.5 HP	0'	100'
2 HP	0'	160'
3 HP	60'	280'
<b>30 GPM Series</b>		
1 HP	0'	10'
1.5 HP	0'	20'
2 HP	0'	90'
3 HP	10'	240'
<b>Jet Pumps</b>		
1/2 HP	10 + PSI	5'
3/4 HP	0 + PSI	15'
1 HP	0 + PSI	20'
1.5 HP	0 + PSI	25'
2 HP	0 + PSI	25'
<b>Replaces controllers on most variable speed pumps</b>		
Contact the factory if your pump, depth, or pressure is not listed above.		

# Replaces VFD Controllers

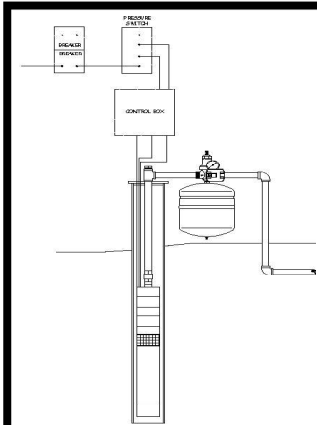

## Instructions to Replace Grundfos® CU301 Controller

Installation for SQE® controller replacement

- 1) Remove CU301 controller and transducer
- 2) Install **pside-kick®**
- 3) Wire pressure switch as per instructions

## Instructions to Replace Franklin® Monodrive® and Subdrive® 3 PH

Instructions for Monodrive® replacement

- 1) Replace Monodrive® controller with standard 1 Phase control box.
- 2) Remove micro switch and plug hole
- 3) Install **pside-kick®** and wire power through pressure switch as per diagram.

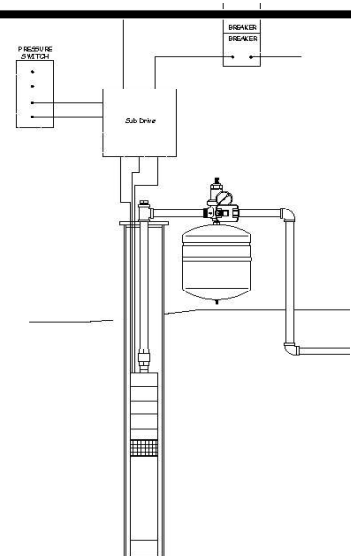

## Instructions for Subdrive® using 3 phase motors, (if replacing microswitch when Subdrive® controller still works or when using other 3 phase converters.)

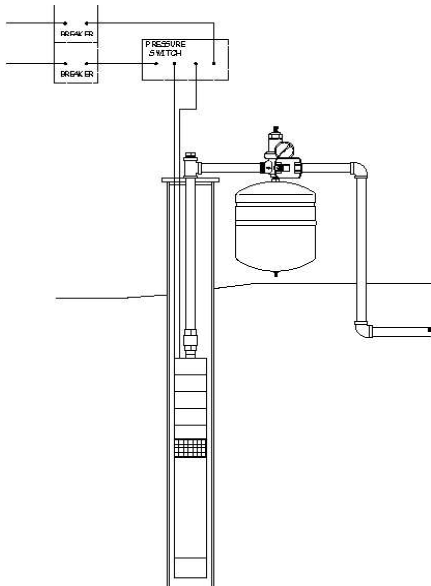

- 1) Install **pside-kick®** per instructions.
- 2) Remove micro switch and move wires to the provided 40/60 pressure switch as per diagram.
- 3) Wire controllers independent 2 wire on/off control to pressure switch as per diagram, or when Subdrive® controller fails
- 1) Install **pside-kick®** per instructions.
- 2) Replace three phase motor and Subdrive® controller with a standard single phase motor and control box.
- 3) Wire pressure switch as per diagram on page 37.

Note: Verify existing pump wire size will work for 1 phase applications.



# Cycle Sensor Pump System Monitor

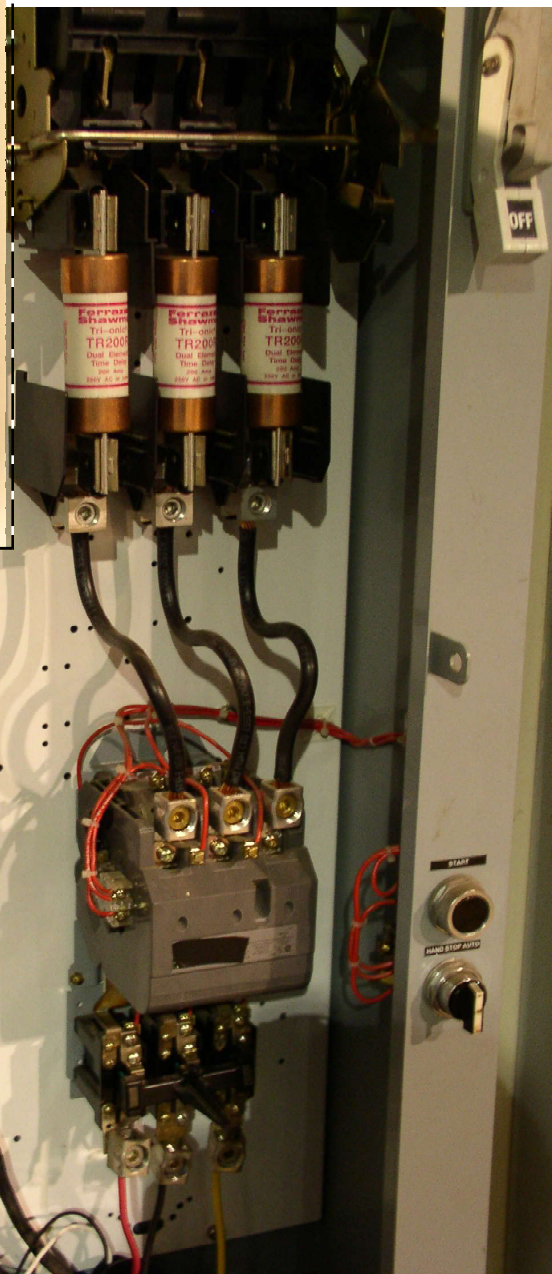
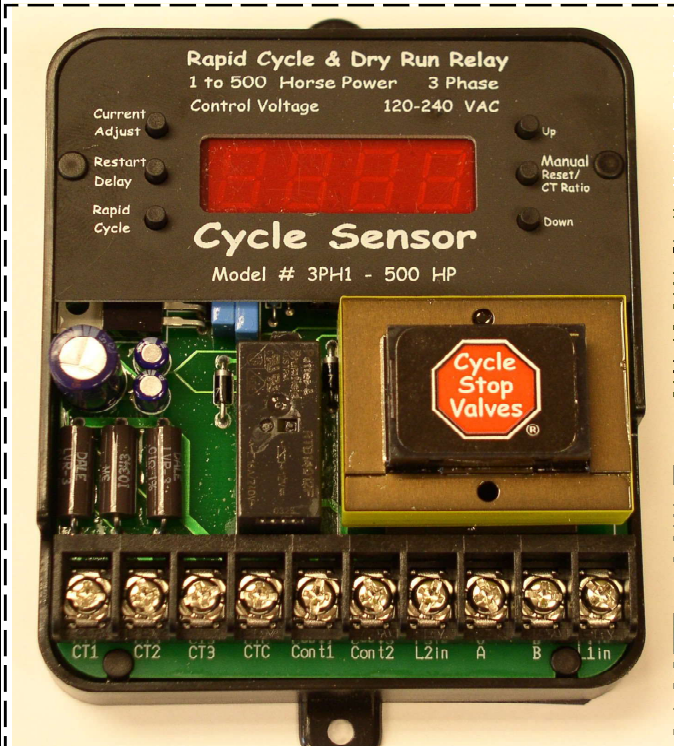



# Cycle Sensor



The Cycle Sensor is a system monitor that detects Rapid Cycle and Dry Run and reacts to either of these conditions by shutting down the pump. It does not control or prevent rapid cycle or dry run but protects your pump in the event these problems occur. This sensor was designed for a pump that is controlled with a Pump Control Valve such as a Cycle Stop valve and/or is installed with enough pressure tanks to prevent a rapid cycle condition. The pump must also be supplied with enough fluid to prevent dry run which causes the undercurrent condition.

These units continuously display the load characteristics of the motor when it is running. When a fault is detected, the relay will shut off power to the pump and display RCYCL for Rapid Cycle or DRY for a Low Current condition. The unit can be reset by pressing the manual reset button or by shutting off power to the unit and then powering back on.

The "Rapid Cycle" feature of this relay monitors the duration of time the pump is on. If the pump "run time" is shorter than the Cycle Sensor minimum set time, the pump will be shut down before damage from cycling occurs. Length of acceptable minimum pump run time is adjustable and can be set for as little as 0 seconds to as much as 600 seconds. (Rapid cycling can be caused by water logged or improperly sized tanks, improper pressure switch settings, control malfunctions, broken check valves, and chattering contacts.)

This "Rapid Cycle" feature only allows for a manual reset. This means that when a rapid cycle is detected, the pump is turned off and it will remain off until the Cycle Sensor is manually reset. Undetected "short cycling" can lead to multiple problems such as submersible pumps unscrewing themselves from the drop pipe and falling into the well, water hammer, contact failure, stripped splines or couplings, broken pump or motor shafts, and ultimately system failure.

The "Dry Run" feature of the Cycle Sensor, unlike other similar relays that look for dry run conditions, can detect the minute differences between the low current achieved when the pump is restricted by a Cycle Stop Valve (or any other valve that restricts the pump to match a low flow demand), and the slightly lower current that occurs when the pump has actually run dry. (For example, if the inlet to the pump became clogged with debris and low current is not detected at this point, the pump and or motor could be destroyed from a lack of cooling flow. Low current can also be caused by cavitation and broken pump shafts or couplings). After a 10 second delay, the pump will be shut down before damage from running dry can occur.

This "Dry Run" feature allows for either a manual reset or a timed restart. The timed restart is adjustable from 0 minute to 300 minutes to allow low producing wells to recover before the pump automatically restarts. The manual reset option is designed to protect systems where the loss of the water supply would be out of the ordinary but a possibility.

Note: Standard overloads do not detect dry run or rapid cycle conditions until damage has occurred and some part of the electrical system has failed. The Cycle Sensor does not control or monitor overload conditions nor is it meant to replace standard overloads, which normally come in the motor or motor starter.

The Cycle Sensor is available in three models:

Model CS1PH1-2HP works with 230V single phase pumps from 1/3HP to 2HP,  
Model CS1PH3-15HP works with single phase pumps from 3HP to 15HP, and  
Model CS3PH1-500HP works with three phase pumps from 1HP to 500HP.



# Cycle Sensor Specifications

## Features

- \* Digital readout of current and set points
- \* More accurate than standard pump protection
- \* Set points are stored on power loss
- \* Adjustable rapid cycle set point
- \* Manual reset on rapid cycle
- \* Adjustable dry run set point
- \* Adjustable restart delay on Dry Run
- \* Optional lock protection feature
- \* Compact size

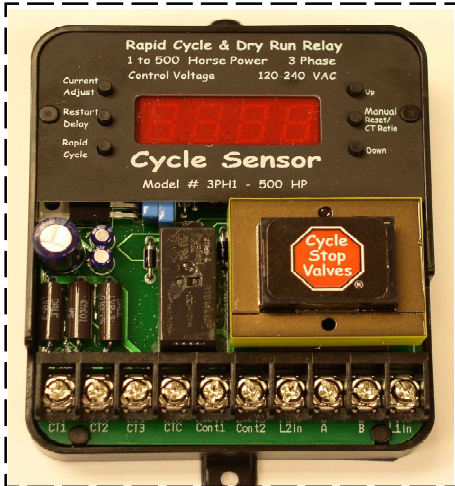

### Model CS1PH1-2HP

Input voltage	190-264 vac (230V)
Frequency	50- to 60 hz
Output rating	1/3 to 2HP at 240 vac
Horse power ranges	1/3 to 2HP
Dry run adj range	1.0 to 15.0 amps
Dry run trip delay	10 seconds
Restart delay range	1-300 min ; 0 for manual reset
Rapid cycle adj range	0 to 600 seconds
Ambient operating temp	-4 to 122 degrees F
Dimensions	4.524 X 3.524 X 1.750 (LWH)

### Model CS1PH3-15HP

Input voltage	190-264 vac
Frequency	50- to 60 hz
Output rating	600 VA at 240 vac
Horse power ranges	3 to 15HP
Dry run adj range	10 to 75 amps
Dry run trip delay	10 seconds
Restart delay range	1-300 min; 0 for manual reset
Rapid cycle adj range	0 to 600 seconds
Required CT ratio	50 : 5
Ambient operating temp	-4 to 122 degrees F
Dimensions	4.524 X 3.524 X 1.750 (LWH)

**Operating Parameters**

### Model CS3PH1-500HP

Control voltage	95-132 vac (115 volt range) 190-264 vac (230 volt range)
Frequency	50- to 60 hz
Output rating	600 VA at 240 vac
Horse power ranges	1 to 500 HP (CT's required)
Dry run adj range	0 to 7.5 amps (50:5 CT w/10 passes) 7.6 to 37.5 amps (50:5 CT w/2 passes) 38-75 amps (50:5 CT w/1 pass) 75 to 375 amps (250:5 CT w/1 pass) 376 to 750 amps (500:50 CT w/1 pass)
Dry run trip delay	10 seconds
Restart delay range	1 to 300 min; 0 for manual reset
Rapid cycle adj range	0-600 seconds
Ambient operating temp	-4 to 122 degrees F
Dimensions	4.524 X 3.524 X 1.750 (LWH)

# Pressure Tank Sizing



## Old Pressure Tank Sizing Method:

In the past, pressure tanks were sized to store at least 1 or 2 gallons of water for every gallon per minute the pump can produce. A 10 GPM pump needed a pressure tank that holds 10 or 20 gallons. A 20 GPM pump needs a tank with 20 to 40 gallons of storage.

Almost 2/3's or more of a tanks volume is filled with compressed air, it takes a very large tank to hold 10 to 40 gallons of water. The higher the pressure switch setting, the less water volume a tank can store.

The following charts show the drawdown of tanks from 2 to 119 gallon actual size, with 40/60 compared to 60/80 pressure switch settings.

**40/60 Pressure Switch Setting**

Tank Size (Gallons)	Tank Drawdown (Gallons)
2.00	0.54
4.40	1.18
8.60	2.30
10.30	2.76
14.00	3.75
20.00	5.35
32.00	8.57
34.00	9.10
44.00	11.78
62.00	16.60
86.00	23.03
119.00	31.86

**60/80 Pressure Switch Setting**

Tank Size (Gallons)	Tank Drawdown (Gallons)
2.00	0.42
4.40	0.93
8.60	1.82
10.30	2.18
14.00	2.96
20.00	4.22
32.00	6.76
34.00	7.18
44.00	9.29
62.00	13.09
86.00	18.16
119.00	25.13



CSV1A with 4.4 Gallon Tank

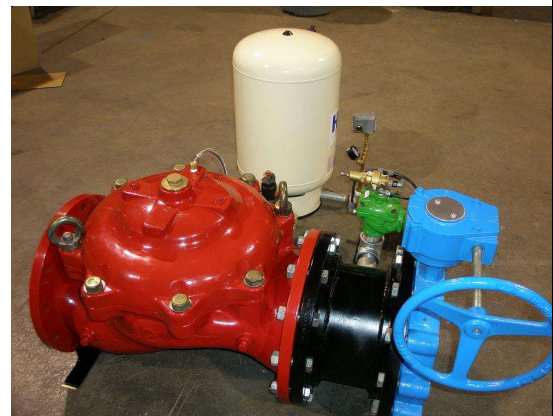

5000 GPM, 12" CSV with 60 gal tank



# Pressure Tank Sizing

A pressure tank supplies water as the pressure drops from 60 to 40 PSI. At 40 PSI the pressure switch starts the pump, the pump fills the pressure tank to 60 PSI, and the pressure switch shuts off the pump. This is called a cycle. Cycling the pump on and off causes almost every problem with pump systems.

The maximum number of cycles allowed for a 1 HP pump to survive is 100 times per day. The average person in the US uses 75 gallons per day. Just one or two people in the house can use enough water to cycle the pump many times per day. Add a sprinkler, an open loop heat pump, or just a few kids, and that can easily cause more than 100 cycles per day. Larger pressure tanks reduce the number of cycles, but they don't stop cycling.

Cycling causes the premature destruction of pumps, motors, pressure switches, relays, capacitors, check valves, and even the pressure tank. Cycling causes water hammer which pounds on faucets, seals, washers, appliances, pipe, and pipe-fittings. Cycling the pump can cause the house lights to flicker and annoying swings in shower pressure. Cycling can cause pump wire chaffing, pumps coming unscrewed, noise, and high electric bills. Even problems with minimum flow for tankless water heaters can be attributed to cycling.

A Cycle Stop Valve (CSV), as the name implies, stops pumps from cycling. When water is being used, the pressure tank drains and the pressure switch starts the pump. The CSV then varies the flow from the pump to match the amount being used. Water flows past the pressure tank, directly to the faucet, at a constant 50 PSI. Only when all the faucets have been turned off, will the CSV allow 1 GPM to slowly fill the pressure tank to 60 PSI, and the pressure switch shuts off the pump.

Although a CSV will work with any size pressure tank, larger pressure tanks are no longer needed. With a CSV, a 4.4 gallon size tank, which holds 1 gallon of water, is sufficient for any size house. Larger pressure tanks are simply a waste of money and space.

Most size pressure tanks can be used with the CSV. Go to the following link on our website to enter your specific system information in the calculator

[http://www.cyclestopvalves.com/runtime\\_app.php](http://www.cyclestopvalves.com/runtime_app.php)

## Recomended Pressure Tank Sizes

Model	CSV125-1	CSV125-3
<u>Application</u>	<u>Drawdown gallons</u>	<u>Drawdown gallons</u>
Irrigation only	1	4
One house	1	5
Three houses	15	15
Five to twenty houses	25	25

Model CSV2 and Model CSV3	
<u>Application</u>	<u>Drawdown gallons</u>
Irrigation only	10
One House	10
Five to twenty houses	30
Large systems	10

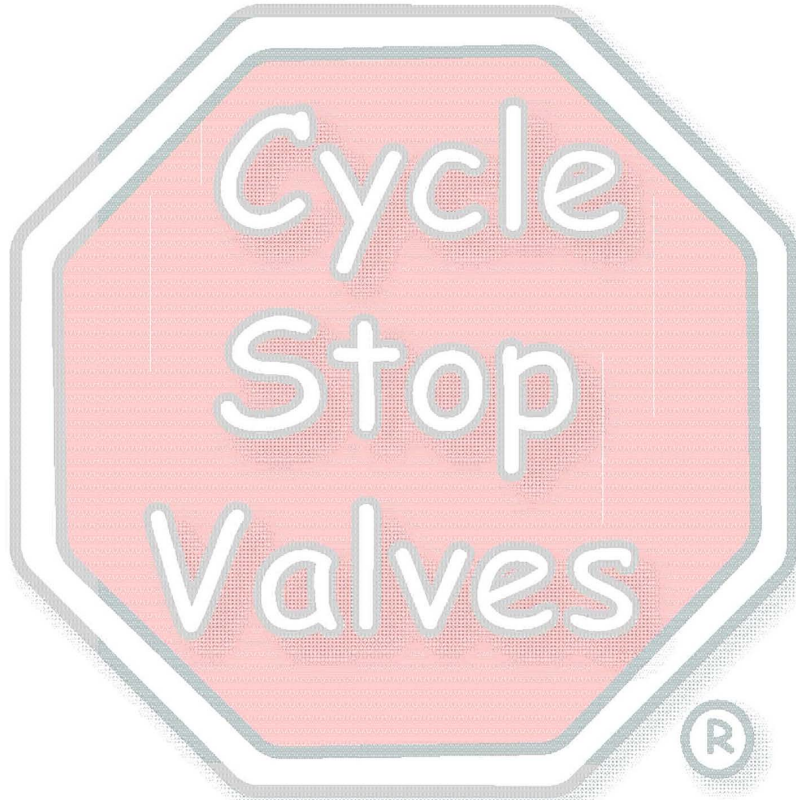

**Help when you need it:**

**Cycle Stop Valves, Inc.**

**10221 CR 6900**

**Lubbock, TX 79407**

**Toll free: 800-652-0207**  
**Telephone: 806-885-4445**  
**Fax: 806-885-1994**

**Email: [info@cyclestopvalves.com](mailto:info@cyclestopvalves.com)**

**Online chat: [www.CycleStopValves.com](http://www.CycleStopValves.com)**



**COASTAL WATER FILTERS**  
WHOLESALE ONLY

Distributed by:

**Coastal Water Filters, Inc**

**435 23rd St. NW**

**Naples, FL 34120**

**239-398-0967**

**[info@coastalwaterfilters.com](mailto:info@coastalwaterfilters.com)**

